

TR-20

KNOWLES ELECTRONICS COMPANY

TECHNICAL NOTES ON THE USE OF THE BU 1771 ACCELEROMETER
CARTRIDGE

These notes are intended as a guide to the use of the BU 1771 accelerometer cartridge. They should not be taken as a specification of this product.

Knowles®

Knowles Electronics Inc.,
3100 North Mannheim Road,
Franklin Park,
Illinois 60131,
U.S.A.
Telephone: 312-455-3600
Cable: Knowlec Chicago

Knowles Electronics Co.
Victoria Road,
Burgess Hill,
West Sussex, RH15 9LP,
England.
Telephone: Burgess Hill (04446) 5432
Cable: Elekno1 Burhill



February 1982

1.0 CONSTRUCTION

The BU is a small, low mass accelerometer designed for use on light-weight structures. The inbuilt FET amplifier and high shock resistance also make this device, if mechanically protected, suitable for industrial applications.

The outer casing is type 305 stainless steel, epoxy sealed and with solder pad terminations. It may be safely "potted" with epoxy if required (provided that the temperatures resulting from exothermic reactions are maintained below 100°C).

Most other accelerometers use a high active mass to produce acceptable sensitivity to overcome problems of high impedance amplifiers on the end of long cables. Such a high mass can cause problems with a) weight b) shock susceptibility and c) change in mounted response.

The low mass piezo-electric element and integral FET amplifier overcomes such problems;

- 1) it withstands shocks in excess of 10,000g - (half sine wave for 100 µsec.)
- and
- 2) the dynamic (moving) mass is small (less than 10mgm) compared with the total BU mass (300mgm) so its resonance is little affected by the mass of the object upon which it is mounted.

Below 5KHz the transverse sensitivity is at least 20 dB below the main axis sensitivity.

2.0 MECHANICAL

2.1 Use on Lightweight Structures e.g. Circuit boards, body panels, windows, medical etc.

Use BU unencapsulated to keep low mass. Take care with soldering; use a low powered soldering iron with controlled temperature of $290^{\circ} - 345^{\circ}\text{C}$. It may be necessary to strengthen the lead connections with epoxy adhesive.

Mounting

For use up to 5KHz, double sided tape is adequate. Above 5KHz cyanoacrylate, or epoxy adhesives are fine. At room temperature beeswax is sufficient.

2.2 Use for Machinery Monitoring

The BU should be encapsulated in bubble-free epoxy in a metal housing with suitable mounting facilities.

It is recommended that the source follower mode is used for high accelerations; resistor R_2 (voltage divider circuit) is encapsulated with the BU in the secondary housing which may be earthed. The BU in this application must be electrically insulated from the secondary housing.

3.0 EFFECTS OF TEMPERATURE

The BU will operate at 70°C with a nominal 10% increase in sensitivity. It may be stored at 120°C without permanent degradation (it will not operate at this temperature), but care should be taken to avoid rapid temperature changes since these may set up stresses in the piezo-electric beam which will affect sensitivity.

4.0 ELECTRICAL4.1 General

The piezo-electric element is connected internally to an FET amplifier as shown below

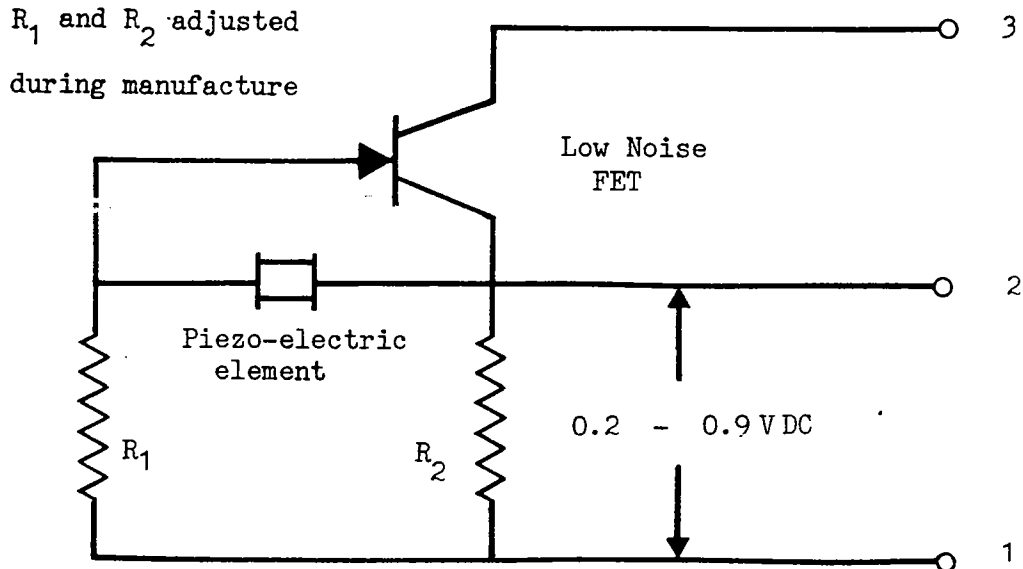

The case is electrically connected to terminal (1) via a resistance of less than 100Ω .

The transducer requires an external power supply which must be free from electrical noise. For the FET to operate, the voltage between terminals 1 and 3 must be greater than 1.1V; it may be destroyed by voltages in excess of 20V.

The power requirement is low and could be supplied by a battery. The output impedance of the BU is dependent upon mode of operation but generally it is low enough to drive several feet of cable without special amplifiers.

Three common methods of use are:

- 1) 3-wire mode
 - simple connection of DC supply across terminals 1 and 3 then output taken from terminal 2 - high sensitivity mode.
- 2) 2-wire mode
 - uses only terminals 1 and 3, for situations where only two connecting wires to the transducer are available.
- 3) Source - follower mode
 - for measurements of high accelerations.

BU 1771 is tested and specified in 2-wire mode, its sensitivity and spread in sensitivity will change for other modes of operation.

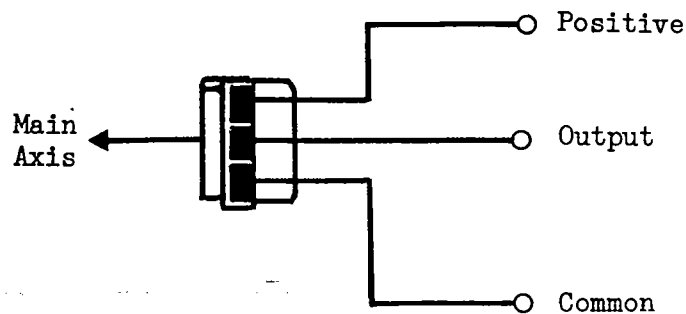
4.2 3-Wire Mode - typical performance

N.B. $g = 981 \text{ cm/sec}^2$

1. Supply voltage : 1.5V DC (range 1.1 to 20V)
2. Standing Current : 30 μA DC (range 20 - 50 μA)
3. Output Impedance : 13K Ω (range 8 - 22K Ω)
4. Response : See Section 6.
5. Sensitivity at 1KHz : ~~30~~⁻³⁷ dB re 1V/g, i.e. 30 mV/g. *typical*
6. Typical Minimum g : at 1KHz for 6 dB signal to noise
.003 g or 3 cm/sec^2
7. Typical Maximum g (peak) : limited by electrical "clipping".
The maximum negative electrical excursion of the output may be typically 0.3V (range 0.2 to 0.9V and governed by production tolerances).

The signal will begin to 'clip' on a negative going acceleration of $\frac{0.3\text{V}}{\text{sensitivity}}$ which is typically 10g.

At resonance the sensitivity is 40 dB higher so clipping occurs (in this instance) at 0.10g.

The FET will cease operation when the voltage across it is reduced below nominally 0.2V.

The maximum positive excursion is therefore

$$V_{\text{supply}} - (0.3 + 0.2) = 1\text{V}$$

8. Phase Acceleration directed to the arrowed direction of the main axis results in a positive output.

4.3 2-Wire Mode

- Where only two connecting leads are available.

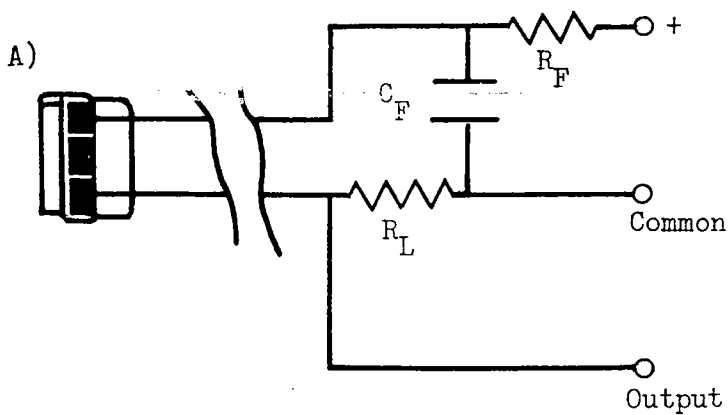

Same phase as 3 wire mode
Case must not be grounded

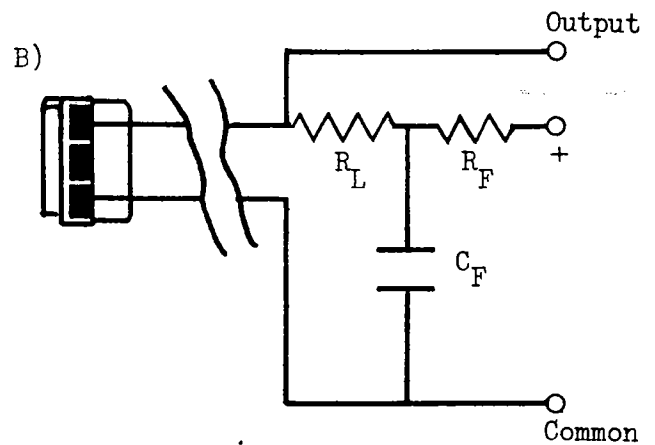

Reversed phase
Case grounded
Power supply 'feed through'
is higher.

$$R_F \leq 2K\Omega, \quad C_F \geq 1 \mu f, \quad R_L < 20K\Omega \text{ (typically } 4K\Omega \text{)}$$

A change to R_L will alter the sensitivity of the circuit.

R_F and C_F decouple the power supply and are not necessary if battery powered, or supply ripple is very low.

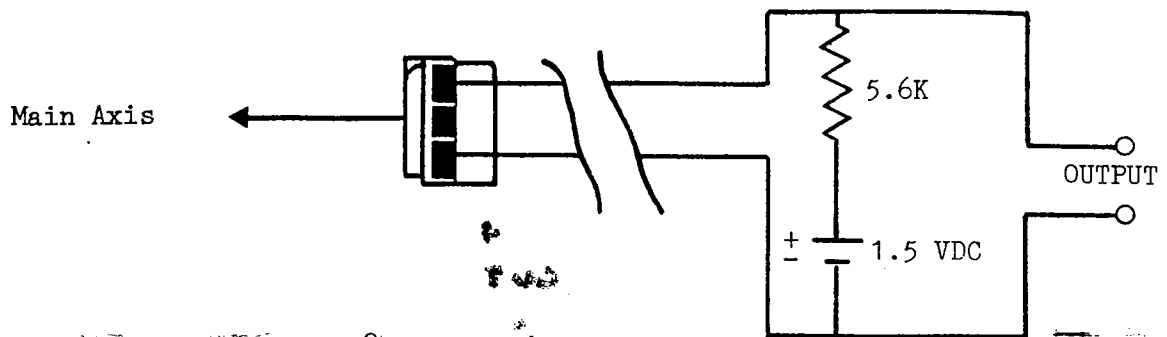
Typical results for 2-wire (type B) connection

N.B. $g = 981 \text{ cm/sec}^2$

1. Supply Voltage : 1.5V DC, (range 1.1 to 20V)
2. Standing Current : 30 μA DC (range 20 to 50 μA)
3. Output Impedance : 5.2K Ω (range 4.9K Ω to 5.5K Ω)
4. Response : See section 6.
5. Sensitivity at 1KHz : nominal -45 dB re 1V/g i.e. 5.6 mV/g
range -49.5 to -40.4 dB i.e. 3.3 to 9.4 mV/g
6. Noise (A weighted) : -103 dB max re 1V i.e. 7 μV max.
7. Typical Minimum g : at 1KHz for 6 dB signal to noise
.003 g i.e. 3 cm/sec^2
8. Typical Maximum g (peak) : limited by electrical "clipping"

For a standing current of 30 μA (governed by production tolerances) and a load resistor of 5.6K Ω the maximum positive electrical excursion of the output will be

$$30 \times 10^{-6} \times 5.6 \times 10^3 = 0.168\text{V}$$

The negative excursion is limited by the internal 22K Ω resistance (and the approximately 0.2 minimum voltage across the transistor) for this device the maximum negative excursion will be

$$\left(\frac{1.5 - 0.2}{22000 + 5600} - 3 \times 10^{-6} \right) 5600 = 0.095\text{V}$$

The signal will begin to 'clip' on negative excursions of

$$\frac{0.095}{\text{sensitivity}} = 17 \text{ g (peak)}$$

At resonance the sensitivity is 40 dB higher so in this instance clipping will occur at 0.17 g.

9. Phase Acceleration directed to the arrowed direction of the

4.4. Source-follower Mode

This method of connection overcomes the problem of electrically limiting the output due to the operating point of the FET amplifier.

Two examples are:

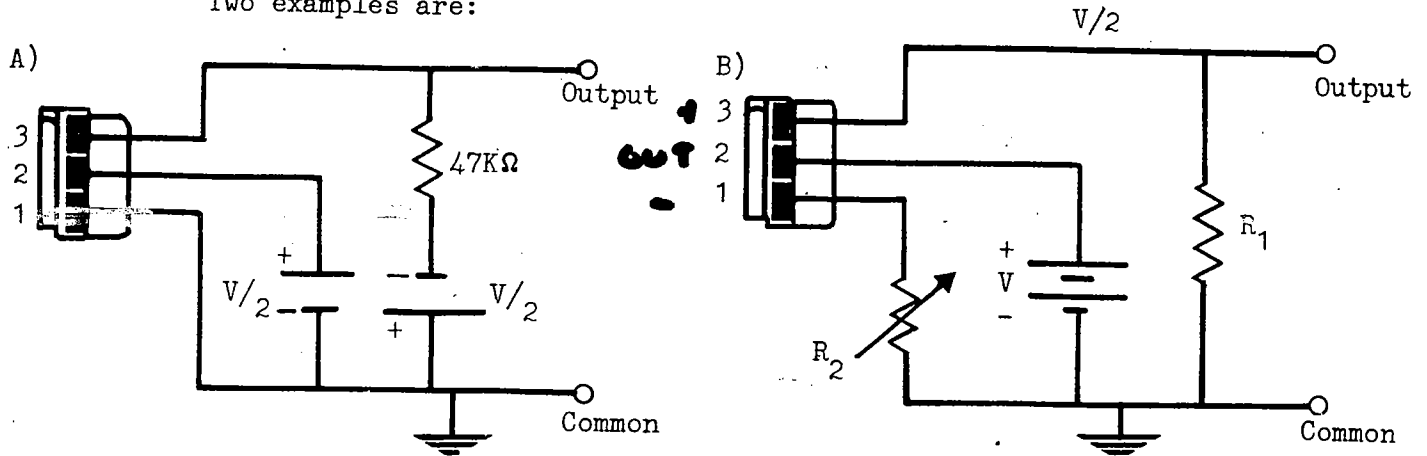

Dual Supply

Case earthed

Voltage Divider

Case not earthed.

Adjust R_2 until half the DC supply volts appear at terminal 3.

R_1 typically $47K\Omega$

Typical results for voltage divider connection

1. Supply (V) 20VDC (range 1.1 to 20V)
2. $R_1 = 47K\Omega$
3. When 10V at terminal 3 $R_2 \sim 20K\Omega$
4. Response : See section 6.
5. Sensitivity at 1KHz -45 dB re 1V/g i.e. 5.6 mV/g
6. Noise : From the transducer $7\mu V$ max. but care must be taken with screening because case is not earthed.
7. Maximum g (peak) : before electrical "clipping"

Electrically the output may move by $\pm V/2$.

Maximum g before clipping = $\frac{V/2}{\text{sensitivity}}$ which in this case is 1780 g at 1KHz and 17 g at resonance.

5.0 Supply Voltage

DC potential between terminals 1 and 3 should be greater than 1.1V for satisfactory operation.

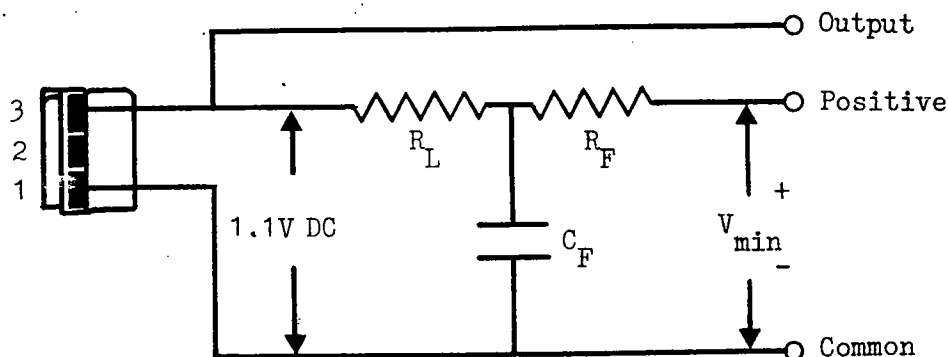

Consider the above 2 wire circuit. Maximum standing current is $50 \mu\text{A}$ then the supply volts V_{min} to give 1.1V across the BU is given by

$$\text{If } R_L = 4\text{K}\Omega \text{ and } R_F = 2\text{K}\Omega$$

then

$$\begin{aligned} V_{\text{min}} &= 1.1 + 50 \times 10^{-6} (R_F + R_L) \\ &= 1.4\text{V typically} \end{aligned}$$

In practice BU will draw less than $50 \mu\text{A}$ therefore it could operate on lower supplies.

Little direct benefit may be gained by increasing the supply voltage above V_{min} because the sensitivity will be nominally unaltered.

However if both R_L and the supply voltage are increased the sensitivity may be raised substantially, but it should be noted that the 'g' for overload will not be appreciably altered. For this type of operation R_L is adjusted so that approximately $V/2$ appears between terminals 1 and 3. The output impedance is then slightly less than R_L .

6.0 RESPONSE

Device Conformity (2 wire Mode)

<u>Frequency (Hz)</u>	<u>Range of Deviation from 1KHz(dB)</u>	
300	- 1.5	+ 1.5
1000	0	0
3000	- 1.0	+ 2.0

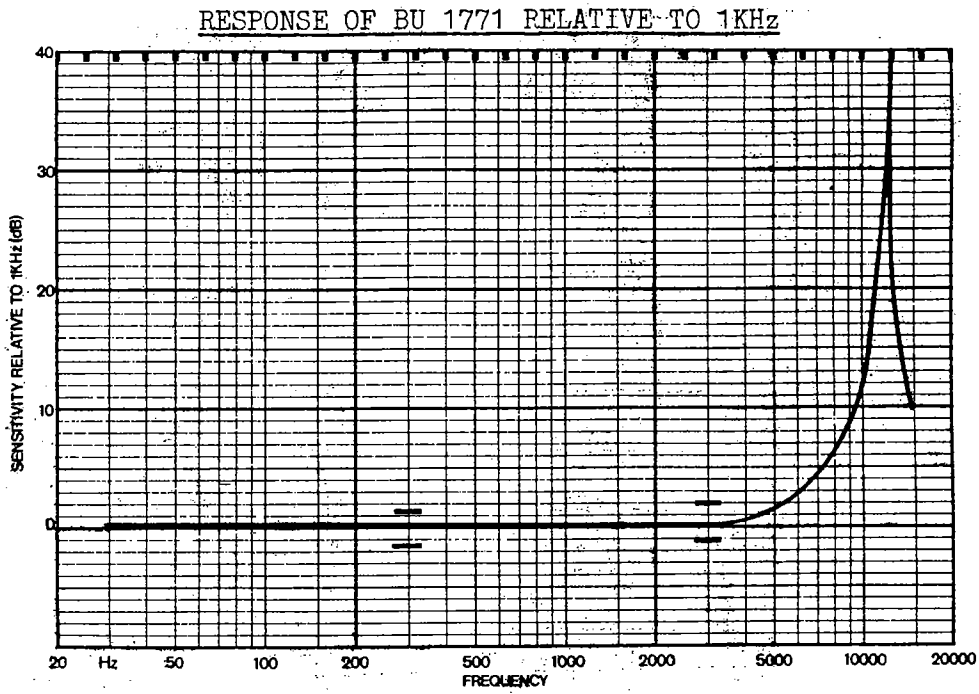

Sensitivity (at 1KHz)

2 wire connection with 5.6K source

nominal	5.6 mV/g
minimum	3.3 mV/g
maximum	9.4 mV/g