

FG-23629-C36

SHT 1.1

NOTES:

1. INCREASED PRESSURE AT THE SOUND INLET CAUSES A POSITIVE GOING VOLTAGE TO APPEAR AT THE OUTPUT TERMINAL, RELATIVE TO THE NEGATIVE TERMINAL.

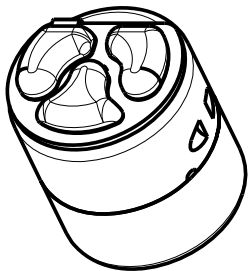
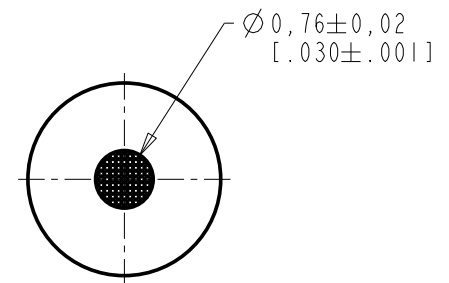
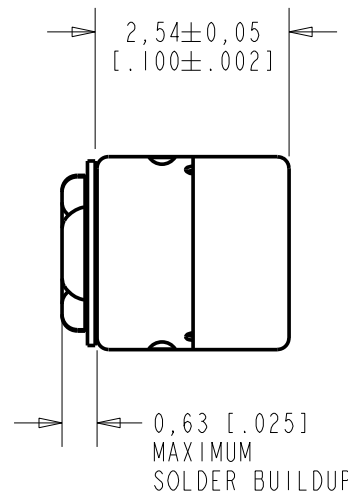
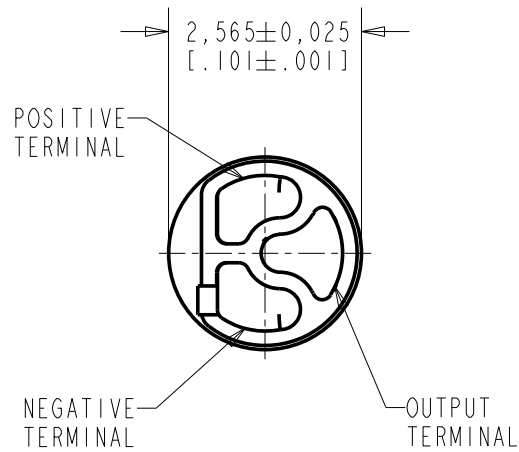

DIMENSIONS IN MILLIMETERS [INCHES]

Revision	C.O. #	Implementation Date	RELEASE LEVEL	REVISION
			Active	D
D	MI0102455	12-23-08		

SCALE:	10:1	DR. BY	DATE
DO NOT SCALE DRAWING		DMS	9-15-05
TITLE:	MICROPHONE	CK. BY	DATE
	OUTLINE DRAWING	GJP	9-26-05
		APP. BY	DATE
		GJP	9-26-05

KNOWLES ELECTRONICS
ITASCA, ILLINOIS U.S.A.

FG-23629-C36

SHT 1.1

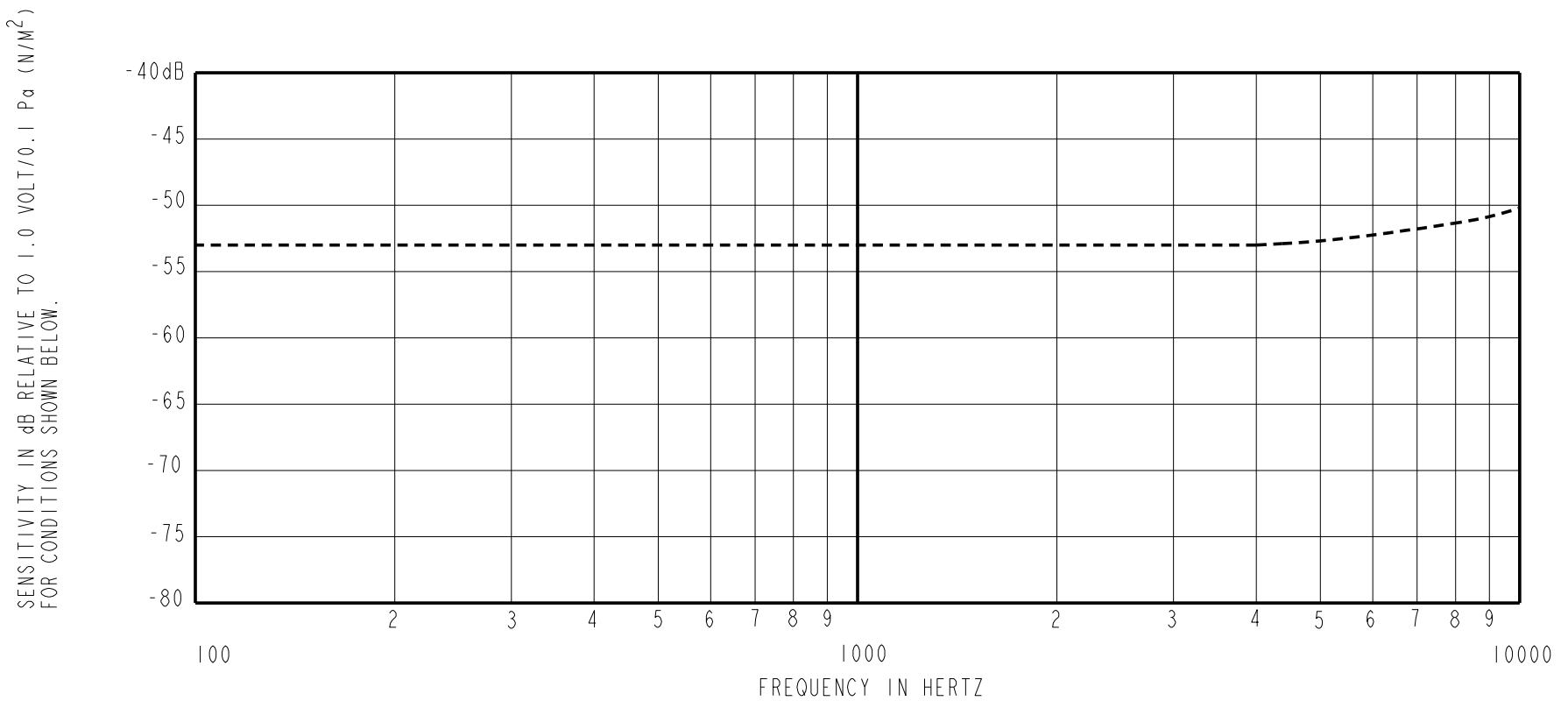

FREQUENCY	SENSITIVITY			DEVICE CONFORMITY	
	MIN.	NOM.	MAX.	RANGE OF DEVIATION FROM 1KHz	
100	---	-53.0	---	-3.0	+3.0
1000	-56.0	-53.0	-50.0	0.0	0.0
10000	---	-50.0	---	-0.0	+6.0

- NOTES: 1. CASE CONNECTED TO NEGATIVE TERMINAL.
2. MICROPHONE TO BE FUNCTIONAL WITH 1.6 VDC SUPPLY.
3. TYPICAL SENSITIVITY TO HUMIDITY AT 1000Hz IS 0.06 dB/%RH
4. SENSITIVITY AND NOISE VALUES INDICATED ON THIS SPECIFICATION ARE VALID AT 50% HUMIDITY.

PORT LOCATION	DC SUPPLY	AMPLIFIER CURRENT DRAIN	SENSITIVITY CHANGE ON REDUCING SUPPLY TO 0.9VDC	"A" WEIGHTED NOISE (1 kHz EQUIV. SPL)	OUTPUT IMPEDANCE OHMS			CAPACITANCE ±50%	
					MIN.	NOM.	MAX.	1-2	1-3
12S	1.3V	50 µA MAX.	3 dB MAX.	28.0 dB MAX.	2800	4400	6800	13pF	13pF

CAPACITANCE PROBE POINTS

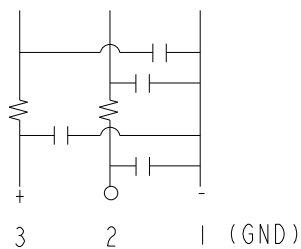

Revision	C.O. #	Implementation Date	RELEASE LEVEL	REVISION
			Active	D
D	MI0102455	12-23-08		
WHEN TEST LIMITS ARE USED TO ESTABLISH INCOMING INSPECTION ACCEPTANCE/REJECTION CRITERIA, CORRELATION OF TEST EQUIPMENT WITH KNOWLES IS ALSO REQUIRED FOR ELIMINATION OF EQUIPMENT AND TEST METHOD VARIATION				
TITLE: MICROPHONE			FG-23629-C36	DR. BY DATE DMS 9-15-05
PERFORMANCE SPECIFICATION			SHT 2.1	CK. BY DATE GJP 9-26-05
				APP. BY DATE GJP 9-26-05

KNOWLES ELECTRONICS
ITASCA, ILLINOIS U.S.A.