

**FHC-23770-102**  
SHT 1.1

NOTE:

 LOCATED FROM TWO SURFACES FOR CUSTOMER CONVENIENCE. ONLY APPLICABLE FROM ONE SURFACE, NOT TO BE USED TOGETHER. HORIZONTAL LOCATION FOR TERMINAL CENTERED TO  $\pm 0,17$  [.007]

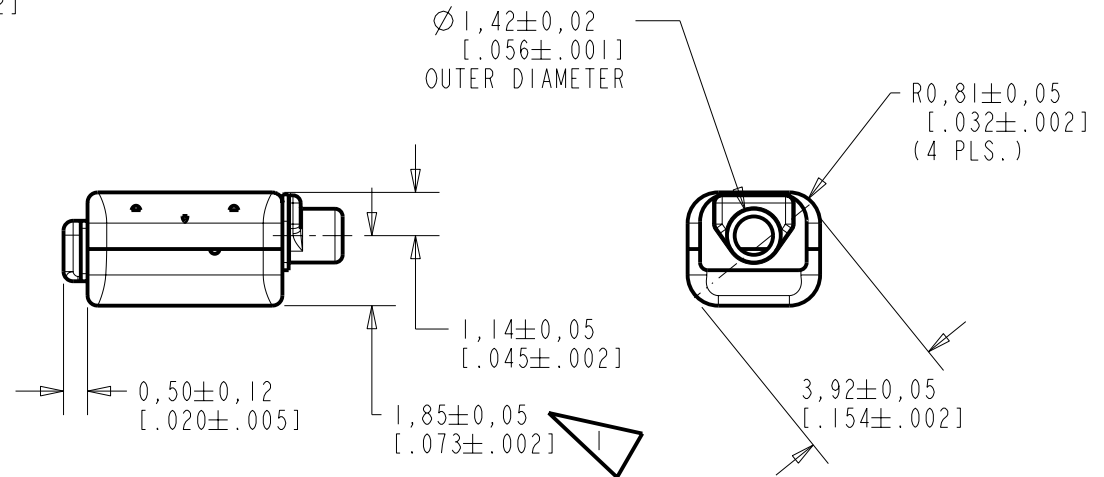
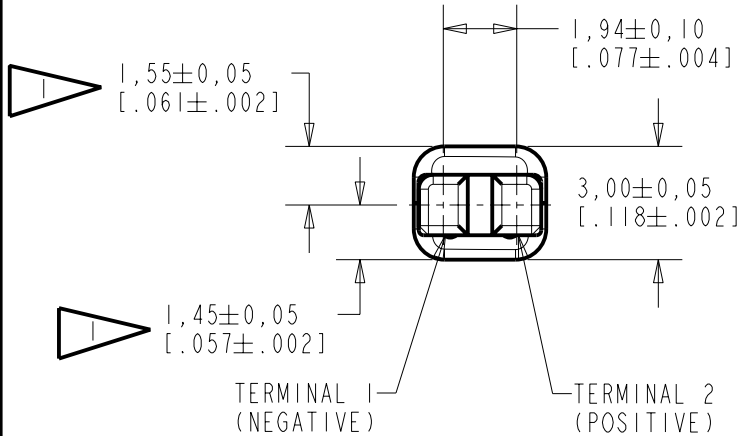
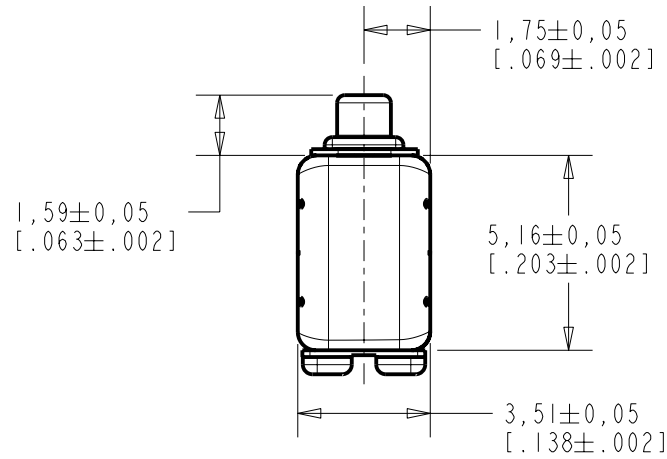

SCALE 2:1

NOMINAL WEIGHT  
.23 GRAMS

DIMENSIONS IN MILLIMETERS [INCHES]

**KNOWLES ELECTRONICS**  
ITASCA, ILLINOIS U.S.A.

Revision	C.O. #	Implementation Date	RELEASE LEVEL	REVISION
B	C10103947	2-22-06	Released	B
A	C10103598	1-25-06		

SCALE: 5:1		DR. BY	DATE
DO NOT SCALE DRAWING		MMM	1-25-06
TITLE: RECEIVER		CK. BY	DATE
OUTLINE DRAWING		GJP	1-26-06
FHC-23770-102		APP. BY	DATE
SHT 1.1		GJP	1-26-06

**DESCRIPTION**

THE FHC-23770-102 IS A MAGNETIC BALANCED ARMATURE RECEIVER INTENDED FOR USE IN ITC AND CIC HEARING INSTRUMENTS. THE HC FAMILY OFFERS 6 dB HIGHER OUTPUT LEVELS IN THE SAME SIZE PACKAGE AS THE FC FAMILY. ALL HC UNITS HAVE SHOCK PROTECTION. THIS MODEL HAS MEDIUM IMPEDANCE AND HAS A PEAK OF 2 dB RELATIVE TO THE SENSITIVITY AT 1kHz.

NOTE: SPECIFICATIONS FOLLOWED BY AN ASTERISK (\*) ARE 100% TESTED.

CONSTANT VOLTAGE DRIVE RESPONSE

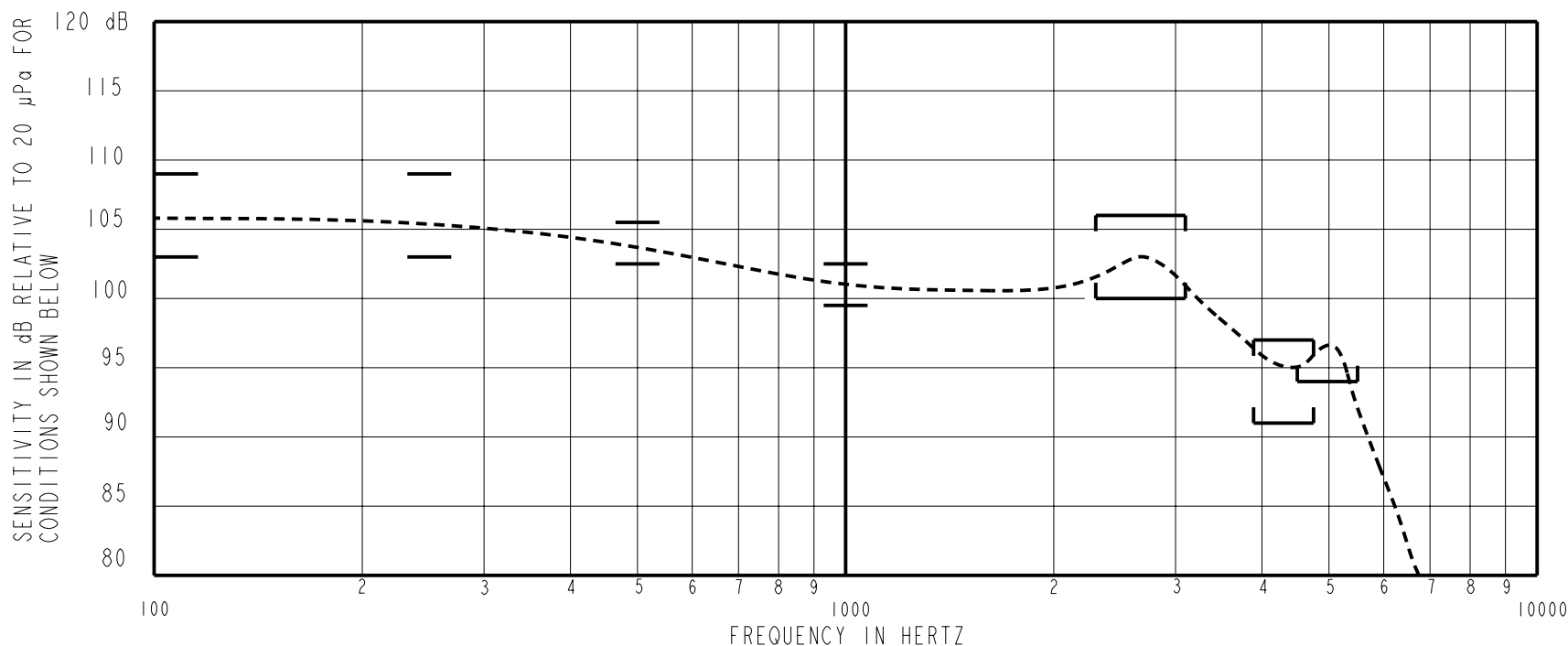

**ACOUSTICAL**

SENSITIVITY\*

DEVICE WILL PRODUCE THE SPL LISTED BELOW WITH THE TEST CONDITIONS DESCRIBED IN TABLES 3. NOMINAL SENSITIVITY AT 1 kHz IS dB RELATIVE TO 20µPa. ALL OTHER VALUES IN dB RELATIVE TO THE SENSITIVITY AT 1 kHz.

FREQUENCY (Hz)	MINIMUM	NOMINAL	MAXIMUM
100	+2.0	+5.0	+8.0
250	+2.0	+5.0	+8.0
500	+1.5	+3.0	+4.5
1000	-1.5	+0.0	+1.5
2300-3100 PEAK	-1.0	+2.0	+5.0
3890-4750 VALLEY	-10.0	-6.0	-4.0
4500-5500 PEAK	-7.0	---	---

TABLE 1.

TOTAL HARMONIC DISTORTION\*

DEVICE WILL NOT EXCEED TOTAL HARMONIC DISTORTION LEVELS LISTED BELOW.

FREQUENCY (Hz)	DRIVE (V RMS)	DC BIAS (MA)	LIMIT (%)
900	.336 V	0	5
1350	.336 V	0	5
500	.948 V	0	10

TABLE 2.

TEST CONDITIONS

NOMINAL SOURCE VOLTAGE	.336 Vrms, 0 Vdc BIAS
SOURCE IMPEDANCE	< 1 Ω
TUBING	10 mm (.394) LONG, 1 mm (.039) ID.
COUPLER CAVITY	2 CC SIMULATED ANSI S3.7 TYPE HA-3, (IEC 126)

TABLE 3.

POLARITY \*

POSITIVE SIGNAL APPLIED TO TERMINAL 2 WILL PRODUCE A DECREASE IN SOUND PRESSURE AT THE SOUND OUTLET.

**ELECTRICAL**

DC RESISTANCE	183Ω ±10%	*
IMPEDANCE @ 500 Hz	290Ω ±15%	
IMPEDANCE @ 1 kHz	530Ω ±20%	*
INDUCTANCE @ 500Hz	73mH ±15%	
CAPACITANCE @ 10 MHz	6pF ±20%	

TABLE 4.

ISOLATION: THE CASE WILL BE ELECTRICALLY ISOLATED FROM THE COIL CIRCUIT\*

MAGNETIC RADIATION

WORST CASE: FIELD WILL BE LESS THAN LEVEL STATED BELOW AT AMPLIFIER CLIPPING (.920 V).

134 dB re 1µA/m

DISTANCE OF 6.3 mm FROM CENTER OF RECEIVER

ANGLE OF 120 DEGREES FROM TUBE

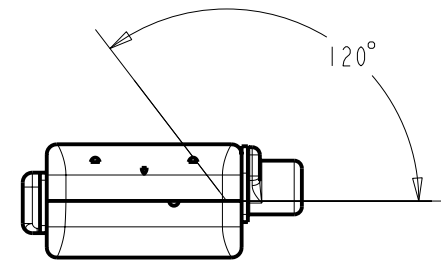

**MECHANICAL**

PORT LOCATION: 12C

SOLDER TYPE: 96.5% Sn, 3% Ag, 0.5% Cu (LEAD FREE)

TEMPERATURE

OPERATING: SENSITIVITY WILL NOT VARY MORE THAN +1/-3 dB FROM -17°C TO 63°C

STORAGE: -40°C TO 63°C

RELIABILITY

UNITS WILL SURVIVE ANY OF THE FOLLOWING ACCELERATED LIFE TESTS, REPORT AVAILABLE FROM QA DEPARTMENT

- HALT TEST (8 WEEKS, 63°C, 95% RH, 0.83V, 500 Hz SIGNAL)
- HIGH TEMPERATURE STORAGE (63°C, 72 HOURS)
- LOW TEMPERATURE STORAGE (-40°C, 72 HOURS)
- DAMP HEAT CYCLING (ALTERNATE 25°C TO 63°C, 93% RH, 20 CYCLES)
- THERMAL SHOCK (-40°C TO 63°C, 5 CYCLES)
- SOLDER/DESOLDER CYCLING (5 CYCLES)
- SOLDER PAD STRENGTH (STRENGTH > 1.8 LBS.)
- STRESS TEST (16.8 V AT 2700 Hz SIGNAL, 1 HOUR)
- MECHANICAL SHOCK
- LEAK TEST AFTER AGING (NO LEAK AFTER ANY OF THE ABOVE TESTS)

Revision	C.O. #	Implementation Date	RELEASE LEVEL	REVISION
B	C10103947	2-22-06	Released	B
A	C10103598	1-25-06		

**KNOWLES ELECTRONICS**  
ITASCA, ILLINOIS U.S.A.

WHEN TEST LIMITS ARE USED TO ESTABLISH INCOMING INSPECTION ACCEPTANCE/REJECTION CRITERIA, CORRELATION OF TEST EQUIPMENT WITH KNOWLES IS ALSO REQUIRED FOR ELIMINATION OF EQUIPMENT AND TEST METHOD VARIATION

TITLE: **RECEIVER** **FHC-23770-102**  
PERFORMANCE SPECIFICATION **SHT 2.1**

DR. BY	DATE
MMM	1-25-06
CK. BY	DATE
GJP	1-26-06
APP. BY	DATE
GJP	1-26-06