

PHF-23851-000
SHT 1.1

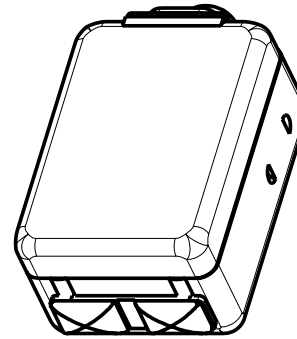
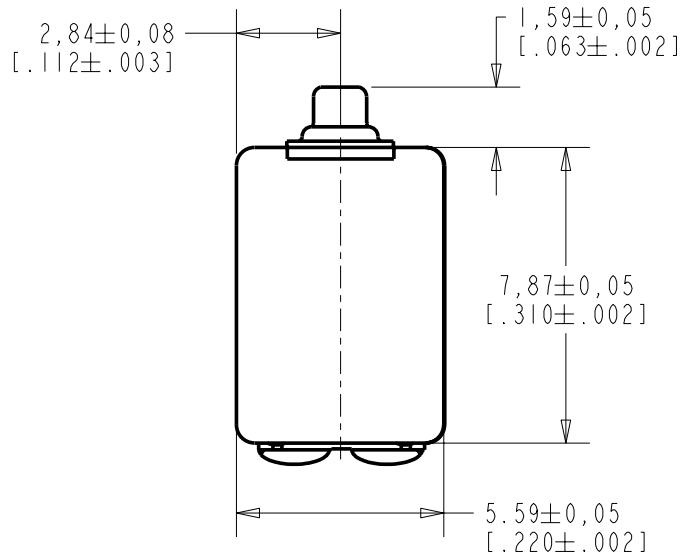

SCALE 5:1

NOTES:

- 1 A POSITIVE GOING VOLTAGE AT TERMINAL 2, RELATIVE TO TERMINAL 1, CAUSES A DECREASE IN PRESSURE AT THE SOUND OUTLET.
- 2 VIBRATION RESPONSE MEASUREMENT: MOUNT UNIT WITH THIS SURFACE CENTERED OVER FORCE TRANSDUCER.

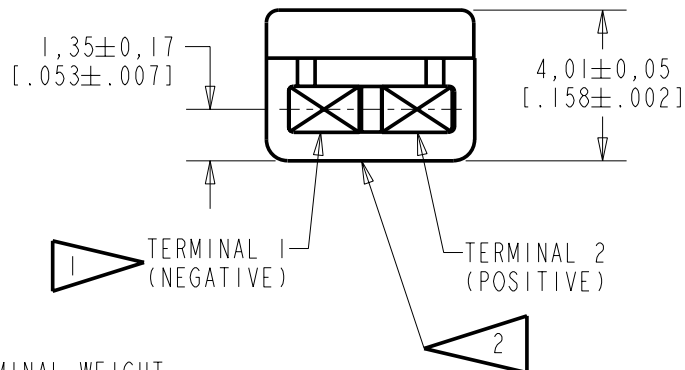

NOMINAL WEIGHT
.71 GRAMS

DIMENSIONS IN MILLIMETERS [INCHES]

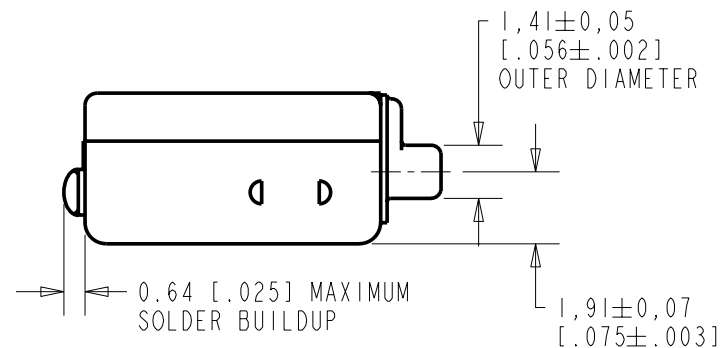

Revision	C.O. #	Implementation Date	RELEASE LEVEL	REVISION
B	C10104508	7-5-06	Released	B
A	C101032446	10-21-05		

SCALE: 5:1		DR. BY	DATE
DO NOT SCALE DRAWING		CRG	10-21-05
		CK. BY	DATE
TITLE: RECEIVER OUTLINE DRAWING		GJP	11-29-05
		PHF-23851-000 SHT 1.1	
		APP. BY	DATE
		GJP	11-29-05

KNOWLES ELECTRONICS
ITASCA, ILLINOIS U.S.A.

DESCRIPTION

NO DAMPING

PHF-23851-000

SHEET 2.1

THE PHF-3851 IS A MAGNETIC BALANCED ARMATURE RECEIVER INTENDED FOR USE IN BTE HEARING INSTRUMENTS. THE PHF FAMILY OFFERS 4 dB HIGHER OUTPUT LEVELS IN THE SAME SIZE PACKAGE AS THE EF FAMILY, AND REDUCED VIBRATION. ALL PHF UNITS HAVE SHOCK PROTECTION. THIS MODEL HAS LOW IMPEDANCE AND IS UNDAMPED.

NOTE: SPECIFICATIONS FOLLOWED BY AN ASTERISK (*) ARE 100% TESTED.

CONSTANT VOLTAGE DRIVE RESPONSE

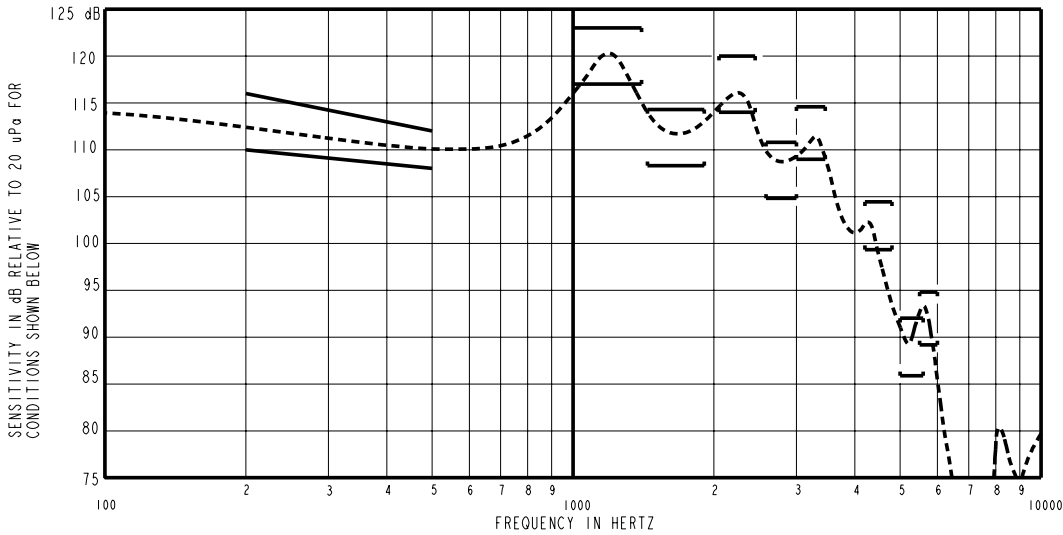

ACOUSTICAL

SENSITIVITY*
DEVICE WILL PRODUCE THE SPL LISTED BELOW WITH THE TEST CONDITIONS DESCRIBED IN TABLE 3. NOMINAL SENSITIVITY AT 500 Hz IS dB RELATIVE TO 20uPa. ALL OTHER VALUES IN dB RELATIVE TO THE SENSITIVITY AT 500 Hz.

FREQUENCY (Hz)	MINIMUM	NOMINAL	MAXIMUM
200	0	+3	+6
500	-2.0	110.0	+2.0
1000-1400 PEAK	+7	+10	+13
1500-1900 VALLEY	-1.7	+1.3	+4.3
2050-2450 PEAK	+4	+7	+10
2600-3000 VALLEY	-5.2	-2.2	+0.8
3000-3500 PEAK	-1.3	+1.7	+4.7
4200-4800 PEAK	-11.5	-8.5	-5.5
5000-5600 VALLEY	-24.0	-21.0	-18.0
5500-6000 PEAK	-21.3	-18.3	-15.3

TABLE 1.

TOTAL HARMONIC DISTORTION*
DEVICE WILL NOT EXCEED TOTAL HARMONIC DISTORTION LEVELS LISTED BELOW.

FREQUENCY (Hz)	DRIVE (V RMS)	DC BIAS (MA)	LIMIT (%)
390	.090 V	0	5
580	.090 V	0	5
500	.360 V	0	10

TABLE 2.

TEST CONDITIONS

NOMINAL SOURCE VOLTAGE	.090 Vrms, 0 Vdc BIAS
SOURCE IMPEDANCE	< 1 Ω
TUBING	8 mm (.315) LONG X 1 mm (.039) ID 28 mm (1.10) LONG X 1.5 mm (.059) ID 25 mm (.984) LONG X 2 mm (.079) ID 18 mm (.710) LONG X 3 mm (.118) ID
COUPLER CAVITY	2 CC SIMULATED ANSI S3.7 TYPE HA-3, (IEC 126)

TABLE 3.

POLARITY
POSITIVE SIGNAL APPLIED TO TERMINAL 2 WILL PRODUCE A DECREASE IN SOUND PRESSURE AT THE SOUND OUTLET.

ELECTRICAL

DC RESISTANCE	9.3Ω ±10%
IMPEDANCE @ 500 Hz	21.7Ω ±15% *
IMPEDANCE @ 1 kHz	56.4Ω ±20% *
INDUCTANCE @ 500Hz	4.7mH ±15%
CAPACITANCE @ 10 MHz	10pF ±20%

TABLE 4.

ISOLATION: THE CASE WILL BE ELECTRICALLY ISOLATED FROM THE COIL CIRCUIT*

MAGNETIC RADIATION
WORST CASE: FIELD WILL BE LESS THAN LEVEL STATED BELOW AT AMPLIFIER CLIPPING (.920 V).
90 dB re 1μA/m
DISTANCE OF 10 mm FROM CENTER OF RECEIVER
ANGLE OF 90 DEGREES FROM TUBE

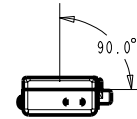

SCALE 2:1

MECHANICAL

PORT LOCATION: 12S

SOLDER TYPE: 96.5% Sn / 3% Ag / 0.5% Cu (LEAD FREE)

TEMPERATURE

OPERATING: SENSITIVITY WILL NOT VARY MORE THAN +1/-3 dB FROM -17°C TO 63°C
STORAGE: -40°C TO 63°C

RELIABILITY

UNITS WILL SURVIVE ANY OF THE FOLLOWING ACCELERATED LIFE TESTS, REPORT AVAILABLE FROM QA DEPARTMENT

HALT TEST (8 WEEKS, 63°C, 95% RH, .360V, 500 Hz SIGNAL)
HIGH TEMPERATURE STORAGE (63°C, 72 HOURS)
LOW TEMPERATURE STORAGE (-40°C, 72 HOURS)
DAMP HEAT CYCLING (ALTERNATE 25°C TO 63°C, 93% RH, 20 CYCLES)
THERMAL SHOCK (-40°C TO 63°C, 5 CYCLES)
SOLDER/DESOLDER CYCLING (5 CYCLES)
SOLDER PAD STRENGTH (STRENGTH > 1.8 LBS.)
STRESS TEST (1.63 Vrms AT 2150 Hz SIGNAL, 1 HOUR)
MECHANICAL SHOCK
LEAK TEST AFTER AGING (NO LEAK AFTER ANY OF THE ABOVE TESTS)

Revision	C.O. #	Implementation Date	RELEASE LEVEL	REVISION
B	C10104508	7-5-06	Released	B
A	C101032446	10-21-05		

WHEN TEST LIMITS ARE USED TO ESTABLISH INCOMING INSPECTION ACCEPTANCE/REJECTION CRITERIA, CORRELATION OF TEST EQUIPMENT WITH KNOWLES IS ALSO REQUIRED FOR ELIMINATION OF EQUIPMENT AND TEST METHOD VARIATION		DR. BY	DATE
		CRG	10-21-05
		CK. BY	DATE
		GJP	11-29-05
		APP. BY	DATE
		GJP	11-29-05

KNOWLES ELECTRONICS
ITASCA, ILLINOIS U.S.A.

TITLE: **RECEIVER** PHF-23851-000
PERFORMANCE SPECIFICATION SHT 2.1

VIBRATION RESPONSE IN DIRECTION PERPENDICULAR TO DIAPHRAGM

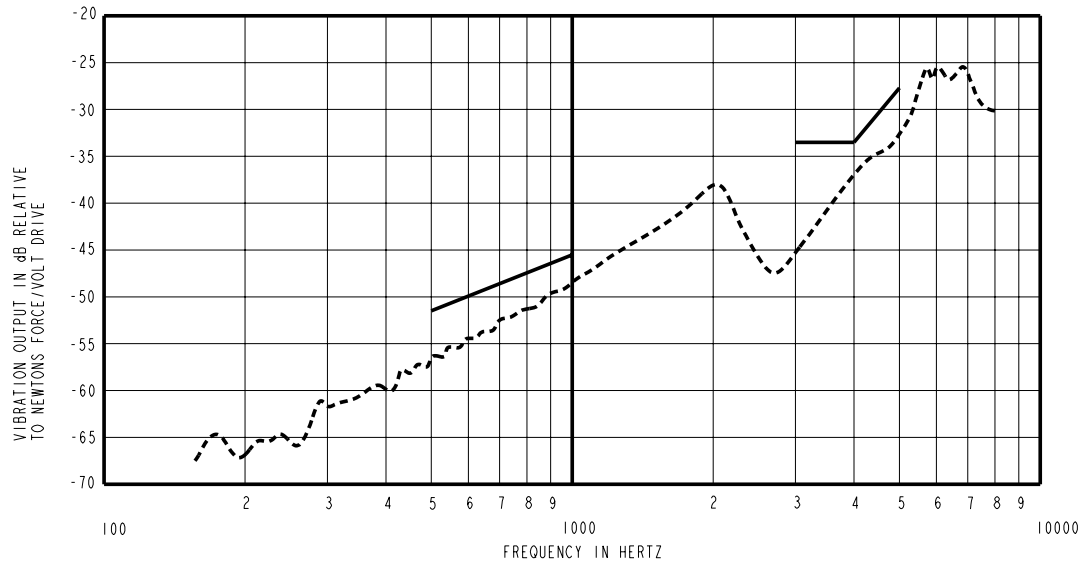

NOTES:

1. VIBRATION RESPONSE

FREQUENCY	MAX.
500	-51.5
1000	-45.5
3000	-33.5
4000	-33.5
5000	-27.7

- VIBRATION RESPONSE MEASURED WITH DEVICE FIXED TO A PIEZOELECTRIC FORCE TRANSDUCER IN THE ORIENTATION DESCRIBED IN THE SHEET 1.1 OUTLINE DRAWING. THIS REPRESENTS THE DIRECTION WITH THE STRONGEST VIBRATION OUTPUT, NORMAL TO THE RECEIVER DIAPHRAGM. THE RECOMMENDED FORCE SENSOR IS PCB PIEZOTRONICS MODEL 208C01 OR FUNCTIONAL EQUIVALENT.
- THE ACOUSTIC OUTPUT IS VENTED TO FREE AIR DURING MEASUREMENT.
- THE UNIT IS TESTED WITH A VOLTAGE DRIVE INPUT CHOSEN FOR SUFFICIENT MEASUREMENT SIGNAL-TO-NOISE RATIO, BUT NOT TO EXCEED 0.36 VRMS.

Revision	C.O. #	Implementation Date	RELEASE LEVEL	REVISION
B	C10104508	7-5-06	Released	B
A	C101032446	10-21-05		

KNOWLES ELECTRONICS
ITASCA, ILLINOIS U.S.A.

WHEN TEST LIMITS ARE USED TO ESTABLISH INCOMING INSPECTION ACCEPTANCE/REJECTION CRITERIA, CORRELATION OF TEST EQUIPMENT WITH KNOWLES IS ALSO REQUIRED FOR ELIMINATION OF EQUIPMENT AND TEST METHOD VARIATION

TITLE: **RECEIVER**
PERFORMANCE SPECIFICATION

PHF-23851-000
SHT 2.2

DR. BY	DATE
CRG	10-21-05
CK. BY	DATE
GJP	11-29-05
APP. BY	DATE
GJP	11-29-05