

VPHF-23872-000

SHT 1.1

NOTES:

1 A POSITIVE GOING VOLTAGE AT THE POSITIVE TERMINAL RELATIVE TO THE NEGATIVE TERMINAL CAUSES A DECREASE IN PRESSURE AT THE SOUND OUTLET.

2 VIBRATION RESPONSE MEASUREMENT: MOUNT UNIT WITH THIS SURFACE CENTERED OVER FORCE TRANSDUCER.

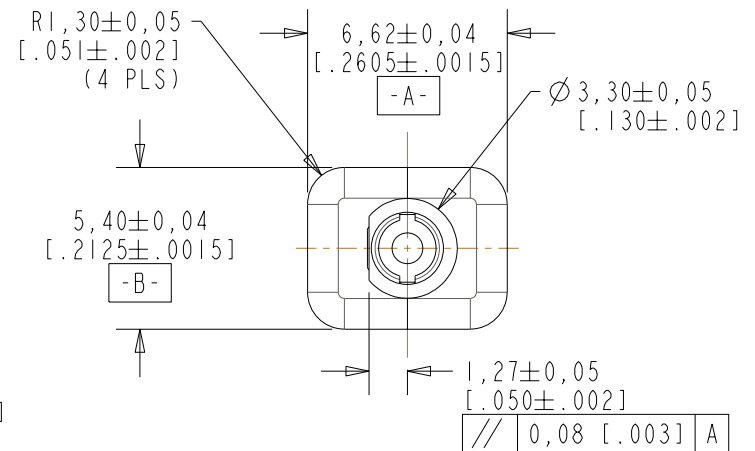
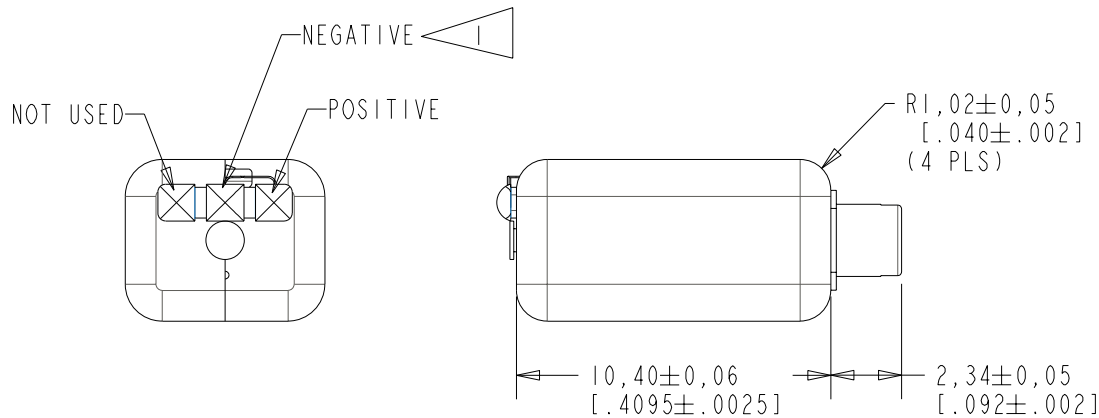
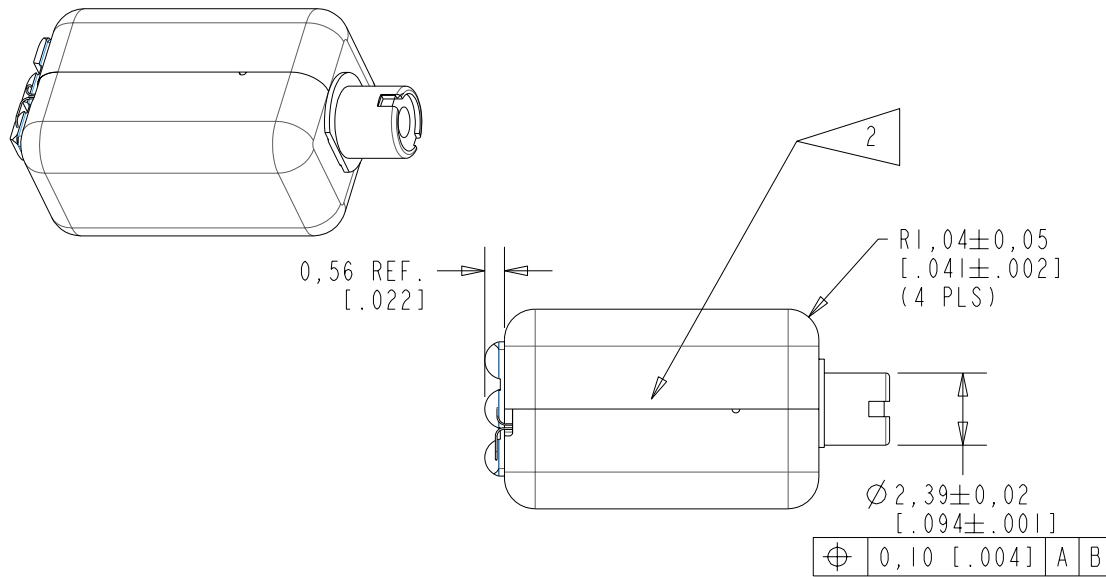

NOMINAL WEIGHT
1.41 GRAMS

DIMENSIONS IN MILLIMETERS [INCHES]

Revision	C.O. #	Implementation Date	RELEASE LEVEL	REVISION
B	C10106936	12-13-07	Active	B
A	C10103196	9-30-05		

SCALE: 4:1	DR. BY: MMM	DATE: 9-30-05
DO NOT SCALE DRAWING	CK. BY: GJP	DATE: 10-3-05
TITLE: VIBRATION ISOLATED RECEIVER	APP. BY: GJP	DATE: 10-3-05
OUTLINE DRAWING	VPHF-23872-000 SHT 1.1	

KNOWLES ELECTRONICS
ITASCA, ILLINOIS U.S.A.

DESCRIPTION

NO DAMPING

VPHF-23872-000
SHEET 2.1

THE VPHF-23872-000 IS A MAGNETIC BALANCED ARMATURE RECEIVER WITH VIBRATION ISOLATION. THE VPHF FAMILY OFFERS 4 dB HIGHER OUTPUT LEVELS IN THE SAME SIZE PACKAGE AS THE PK/VEF FAMILY. ALL VPHF UNITS HAVE SHOCK PROTECTION. THIS MODEL HAS LOW IMPEDANCE AND IS UNDAMPED.

NOTE: SPECIFICATIONS FOLLOWED BY AN ASTERISK (*) ARE 100% TESTED.

CONSTANT VOLTAGE DRIVE RESPONSE

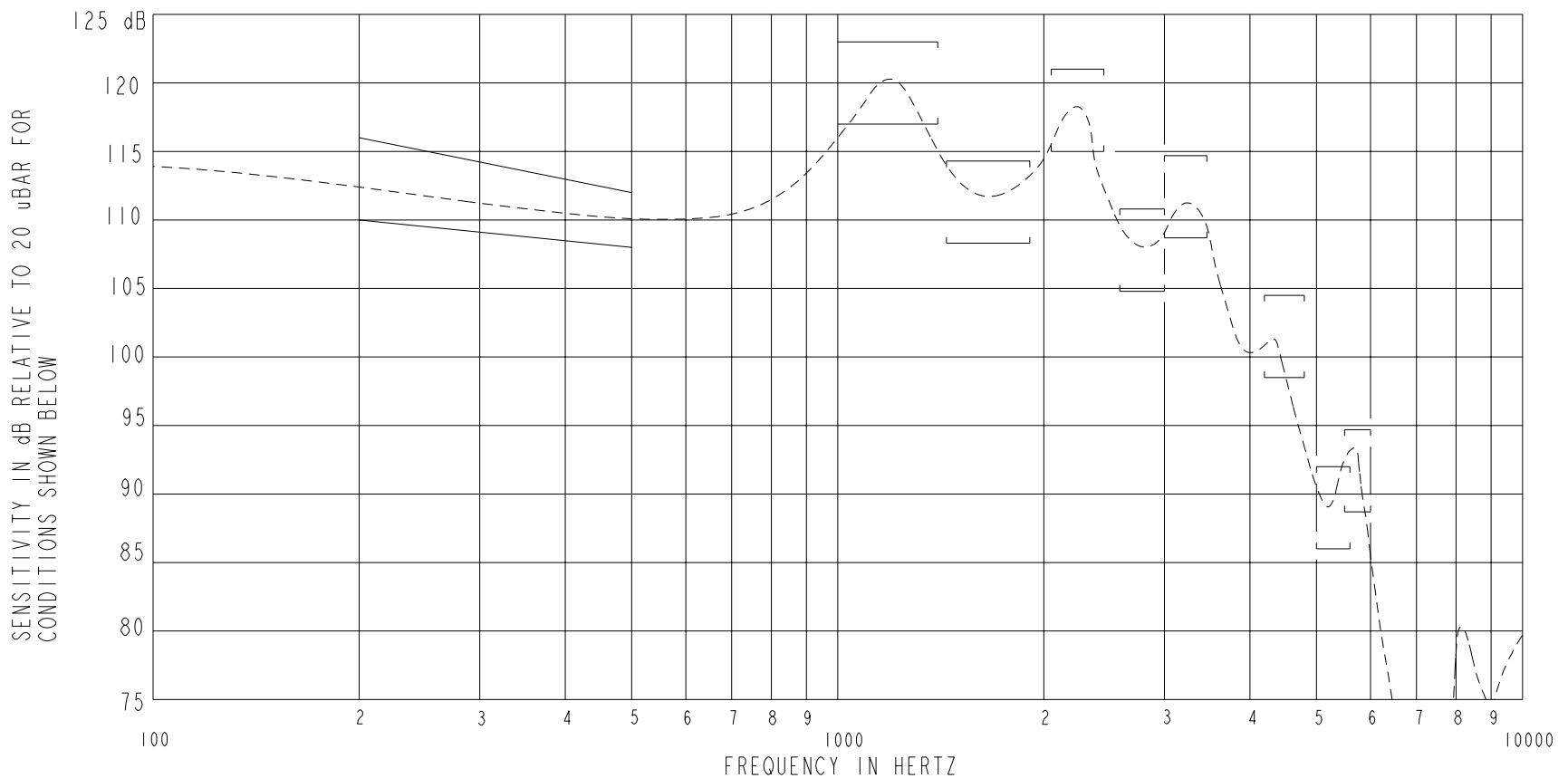

ACOUSTICAL

SENSITIVITY*
DEVICE WILL PRODUCE THE SPL LISTED BELOW WITH THE TEST CONDITIONS DESCRIBED IN TABLE 3. NOMINAL SENSITIVITY AT 500 Hz IS dB RELATIVE TO 20uPa. ALL OTHER VALUES IN dB RELATIVE TO THE SENSITIVITY AT 500 Hz.

FREQUENCY (Hz)	MINIMUM	NOMINAL	MAXIMUM
200	0	+3	+6
500	-2.0	110.0	+2.0
1000-1400 PEAK	+7	+10	+13
1500-1900 VALLEY	-1.7	+1.3	+4.3
2050-2450 PEAK	+5	+8	+11
2600-3000 VALLEY	-5.2	-2.2	+0.8
3000-3500 PEAK	-1.3	+1.7	+4.7
4200-4800 PEAK	-11.5	-8.5	-5.5
5000-5600 VALLEY	-24.0	-21.0	-18.0
5500-6000 PEAK	-21.3	-18.3	-15.3

TABLE 1.

TOTAL HARMONIC DISTORTION*
DEVICE WILL NOT EXCEED TOTAL HARMONIC DISTORTION LEVELS LISTED BELOW.

FREQUENCY (Hz)	DRIVE (V RMS)	DC BIAS (MA)	LIMIT (%)
390	.110 V	0	5
580	.110 V	0	5
500	.440 V	0	10

TABLE 2.

TEST CONDITIONS

NOMINAL SOURCE VOLTAGE	.110 Vrms, 0 Vdc BIAS
SOURCE IMPEDANCE	< 1 Ω
TUBING	8 mm (.315) LONG X 1 mm (.039) ID 28 mm (1.10) LONG X 1.5 mm (.059) ID 25 mm (.984) LONG X 2 mm (.079) ID 18 mm (.710) LONG X 3 mm (.118) ID
COUPLER CAVITY	2 CC SIMULATED ANSI S3.7 TYPE HA-3, (IEC 126)

TABLE 3.

POLARITY
POSITIVE SIGNAL APPLIED TO THE POSITIVE TERMINAL WILL PRODUCE A DECREASE IN SOUND PRESSURE AT THE SOUND OUTLET.

ELECTRICAL

DC RESISTANCE	11Ω ±10%
IMPEDANCE @ 500 Hz	28.8Ω ±20% *
IMPEDANCE @ 1 kHz	77Ω ±20% *
INDUCTANCE @ 500Hz	6.9mH ±15%
CAPACITANCE @ 10 MHz	10pF ±20%

TABLE 4.

ISOLATION: THE CASE WILL BE ELECTRICALLY ISOLATED FROM THE COIL CIRCUIT*

MECHANICAL

PORT LOCATION: 12S

TEMPERATURE
OPERATING: SENSITIVITY WILL NOT VARY MORE THAN +1/-3 dB FROM -17°C TO 63°C
STORAGE: -40°C TO 63°C

RELIABILITY
UNITS WILL SURVIVE ANY OF THE FOLLOWING ACCELERATED LIFE TESTS, REPORT AVAILABLE FROM QA DEPARTMENT

HIGH TEMPERATURE STORAGE (63°C, 72 HOURS)
LOW TEMPERATURE STORAGE (-40°C, 72 HOURS)
DAMP HEAT CYCLING (ALTERNATE 25°C TO 63°C, 93% RH, 20 CYCLES)
THERMAL SHOCK (-40°C TO 63°C, 5 CYCLES)
SOLDER/DESOLDER CYCLING (5 CYCLES)
SOLDER PAD STRENGTH (STRENGTH > 1.8 LBS.)

MECHANICAL SHOCK
LEAK TEST AFTER AGING (NO LEAK AFTER ANY OF THE ABOVE TESTS)

Revision	C.O. #	Implementation Date	RELEASE LEVEL	REVISION
B	C10106936	12-13-07	Active	B
A	C10103196	9-30-05		
WHEN TEST LIMITS ARE USED TO ESTABLISH INCOMING INSPECTION ACCEPTANCE/REJECTION CRITERIA, CORRELATION OF TEST EQUIPMENT WITH KNOWLES IS ALSO REQUIRED FOR ELIMINATION OF EQUIPMENT AND TEST METHOD VARIATION				
TITLE: VIBRATION ISOLATED RECEIVER		VPHF-23872-000		DR. BY DATE MMM 9-30-05
PERFORMANCE SPECIFICATION		SHT 2.1		CK. BY DATE GJP 10-3-05
				APP. BY DATE GJP 10-3-05

KNOWLES ELECTRONICS
ITASCA, ILLINOIS U.S.A.

VIBRATION RESPONSE IN DIRECTION PERPENDICULAR TO DIAPHRAGM

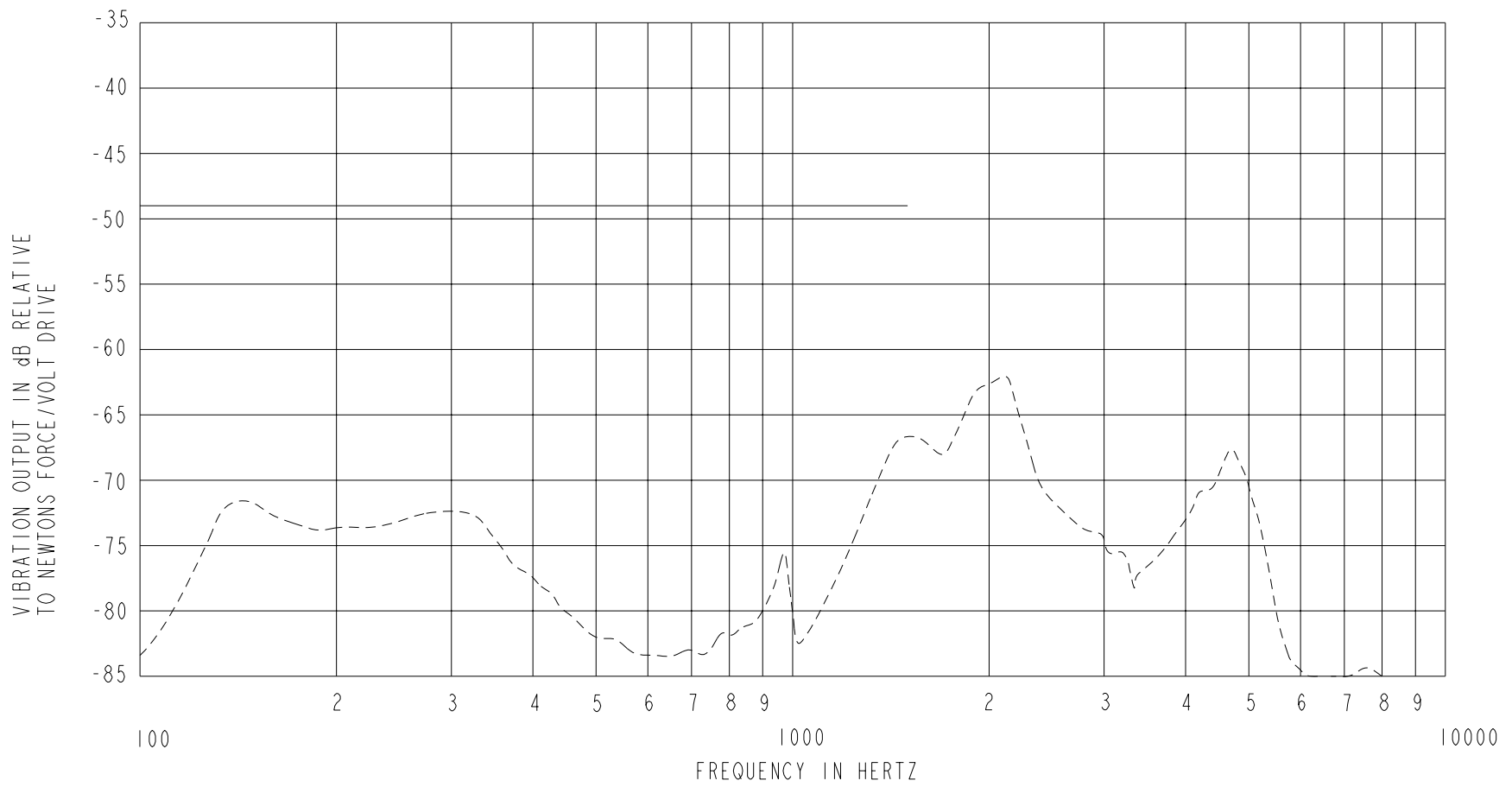

NOTES:

- VIBRATION RESPONSE (dB RELATIVE TO 1 NEWTON FORCE/VOLT DRIVE)

FREQUENCY	MAX.
100-1500	-49.0
- VIBRATION RESPONSE MEASURED WITH DEVICE FIXED TO A PIEZOELECTRIC FORCE TRANSDUCER IN THE ORIENTATION DESCRIBED IN THE SHEET 1.1 OUTLINE DRAWING. THIS REPRESENTS THE DIRECTION WITH THE STRONGEST VIBRATION OUTPUT, NORMAL TO THE RECEIVER DIAPHRAGM. THE RECOMMENDED FORCE SENSOR IS PCB PIEZOTRONICS MODEL 209C11 OR FUNCTIONAL EQUIVALENT.
- THE ACOUSTIC OUTPUT IS VENTED TO FREE AIR DURING MEASUREMENT.
- THE UNIT IS TESTED WITH A VOLTAGE DRIVE INPUT CHOSEN FOR SUFFICIENT MEASUREMENT SIGNAL-TO-NOISE RATIO, BUT NOT TO EXCEED 0.35 VRMS.

Revision	C.O. #	Implementation Date	RELEASE LEVEL	REVISION
B	C10106936	12-13-07	Active	B
A	C10103196	9-30-05		

WHEN TEST LIMITS ARE USED TO ESTABLISH INCOMING INSPECTION ACCEPTANCE/REJECTION CRITERIA, CORRELATION OF TEST EQUIPMENT WITH KNOWLES IS ALSO REQUIRED FOR ELIMINATION OF EQUIPMENT AND TEST METHOD VARIATION		DR. BY	DATE
		MMM	9-30-05
		CK. BY	DATE
		GJP	10-3-05
		APP. BY	DATE
		GJP	10-3-05

TITLE:	VIBRATION ISOLATED RECEIVER	VPHF-23872-000
	PERFORMANCE SPECIFICATION	SHT 2.2

KNOWLES ELECTRONICS
ITASCA, ILLINOIS U.S.A.