



SiSonic Design Guide

Application Note AN24

www.knowles.com

TABLE OF CONTENTS

ABSTRACT.....	3
MEMS MICROPHONE TECHNOLOGY.....	4
CHOOSING THE RIGHT SISONIC MICROPHONE.....	7
PORT LOCATION.....	8
PACKAGE SIZE.....	10
OUTPUT FORMAT.....	11
RF PROTECTION LEVEL.....	14
SENSITIVITY MATCHING.....	14
POWER MANAGEMENT.....	15
MEMS AND ECM MICROPHONES.....	16
MULTI-MIC APPLICATIONS.....	16
MECHANICAL DESIGN CONSIDERATIONS.....	17
CHOOSING THE MIC AND PORT HOLE LOCATIONS.....	18
ACOUSTIC PATH DESIGN.....	18
WIDEBAND FREQUENCY RESPONSE.....	19
ECHO AND NOISE PROBLEMS.....	21
PCB LAND PATTERN AND SOLDER STENCIL PATTERN.....	23
ELECTRICAL DESIGN CONSIDERATIONS.....	25
POWER SUPPLY	25
GROUND.....	24
GAIN CONTROL.....	26
MICROPHONE TO CODEC INTERFACE CIRCUIT.....	27
SISONIC 2-WIRE CIRCUIT.....	27
MINIMIZING NOISE PICK-UP.....	28
MANUFACTURING INFORMATION.....	30
PICK-AND-PLACE SETTINGS.....	31
REFLOW.....	32
REWORK.....	32
HANDLING AND STORAGE.....	33
QUALIFICATION TESTING.....	33
SENSITIVITY MEASUREMENTS.....	34
REVISIONS & ADDITIONAL RESOURCES.....	35

ABSTRACT

SiSonic™ MEMS microphones have gained wide acceptance in many consumer electronics products, including smart phones, feature phones, laptops, tablets, netbooks, headsets, and IoT devices. MEMS microphones are manufactured using silicon wafer processes and have many advantages over traditional ECMs, including smaller size, improved performance, environmental robustness, and suitability for auto pick-and-place processes. This application note explains the package types, output formats, and RF protection levels available in SiSonic microphones. It also provides information on mechanical design, electrical design, and using SiSonic in manufacturing lines.



MEMS MICROPHONE TECHNOLOGY



MEMS MICROPHONE TECHNOLOGY

This section provides short description of MEMS microphone operation. As an example, a simple analog bottom-port microphone is considered. SiSonic MEMS microphone consists of three main parts: MEMS (micro electrical mechanical system), ASIC (application specific integrated circuit) and package.

Sound wave enters the package through the port hole and hits the MEMS. The major elements of the MEMS are backplate and diaphragm which form two plates of a flat capacitor. The backplate is mechanically rigid and has openings that allow air to travel through. The diaphragm is compliant and moves under the impact of the pressure wave.

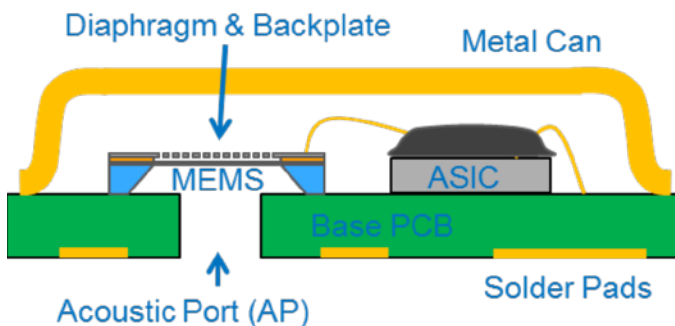

Figure 1: SiSonic microphone

The MEMS element of SiSonic microphone forms a flat capacitor with one motile plate. Thus, the acoustic impact of a sound wave is transduced into an electrical signal by changing the capacitance of the MEMS motor. The backplate and diaphragm are electrically isolated and connected to the ASIC via bond wires. Two major elements of the ASIC are the charge pump and buffer (see below). The purpose of the charge pump is to generate the required bias voltage for the MEMS capacitor. The buffer improves driving capabilities of the device and properly loads the MEMS element.

MEMS MICROPHONE TECHNOLOGY

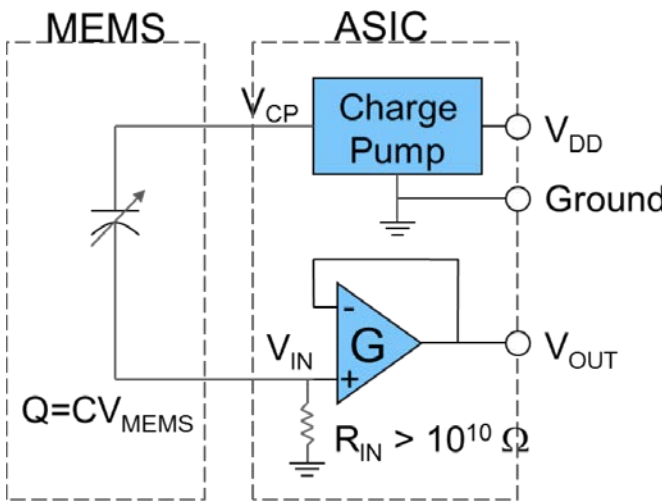

Figure 2: Electric signals in SiSonic microphone

The package design of a SiSonic MEMS microphone also has a critical effect on performance. The dimensions of acoustic elements impact frequency response of the microphone. This concept can be illustrated using an acoustic lumped element model. Compliance is modeled as a capacitor and inertance as an inductor. Below is a typical simplified equivalent circuit and a typical frequency response of SiSonic MEMS microphone. Acoustic low-frequency roll-off is set by the high-pass filter formed by acoustic resistance of the leak through the MEMS and back volume of the package. SiSonic microphones have flat frequency response in audible range. High-frequency resonance peak is mostly defined by the front volume: compliance, inertance and resistance. The signal generator denotes sound pressure wave. Output voltage is taken across the MEMS capacitor (C_{dia}).

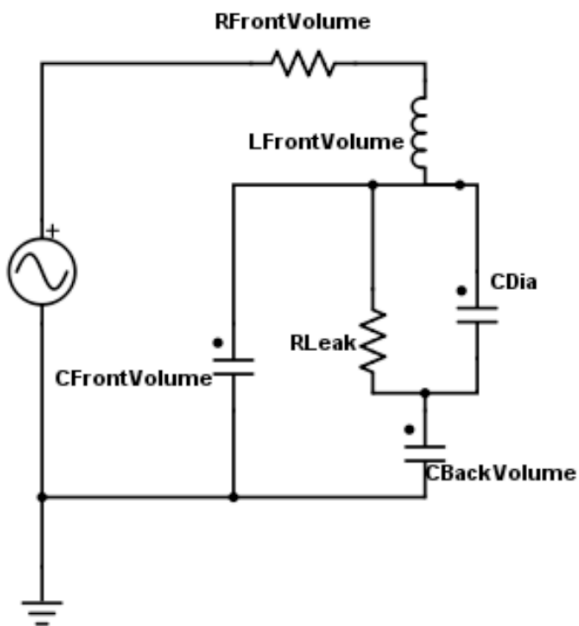
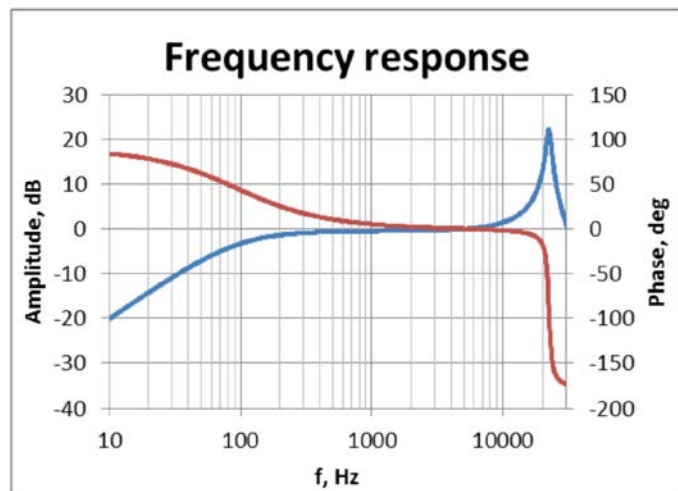

Figure 3: Acoustics of SiSonic microphone



CHOOSING THE RIGHT SISONIC MICROPHONE



CHOOSING THE RIGHT SISONIC MICROPHONE

SiSonic microphone models vary by port location, package size, and output format. The port location and package size are driven by the mechanical requirements of the design, and the output format by the interface chipset and the proximity to antennas and other noise sources. The information in this section will help in choosing the right SiSonic microphone for a particular application.

PORT LOCATION

Diagrams of the basic construction of SiSonic microphones and port-hole locations are shown in the figures below.

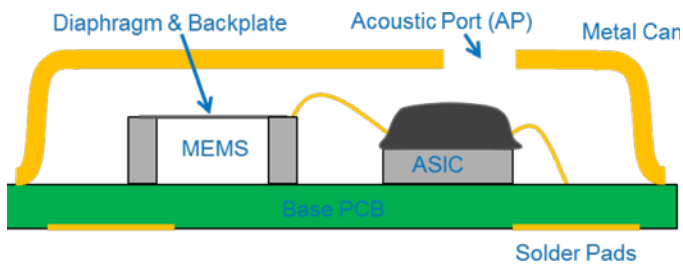

Figure 4: The construction of a top-port SiSonic microphone

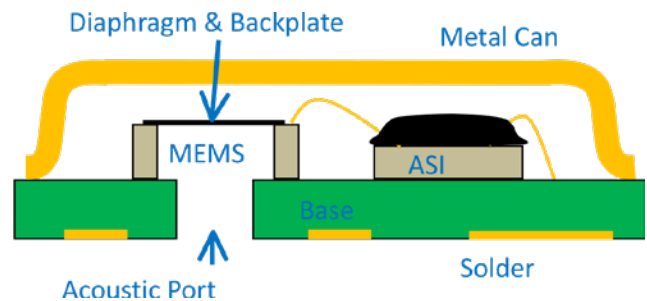

Figure 5: The construction of a bottom-port SiSonic microphone

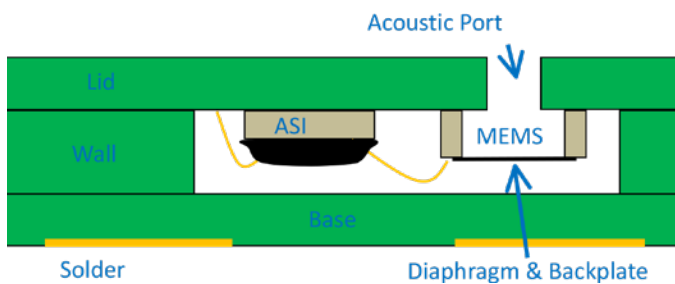

Figure 6: The construction of a MEMS-on-Lid Top-port SiSonic microphone

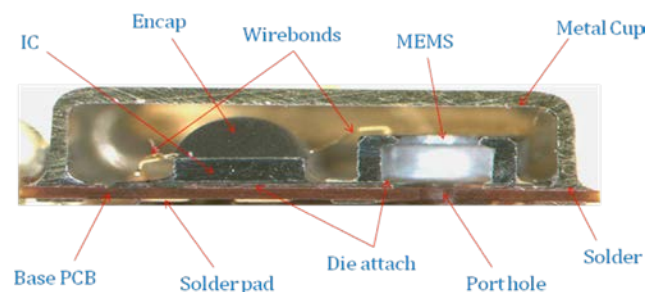

Figure 7: Cross-section a metal can microphone

Top-port SiSonic microphones allow for traditional microphone placement and gasket design, while bottom-port SiSonic microphones are particularly suited for 'thin' product designs where all components are on the opposite side of the PCB from the acoustic port. When bottom-port microphones are used, it is critical to create a continuous solder contact around the port hole to avoid any acoustic leak path through the opening in the solder ring.



CHOOSING THE RIGHT SISONIC MICROPHONE

Front volume is much larger than the back volume for a top-port microphone, while the opposite is true for a bottom-port microphone. These volumes impact frequency response and signal-to-noise ratio (SNR). Generally, bottom-port microphones have a wider frequency response and higher SNR than the top-port microphones. MEMS-on-Lid microphones provide a solution with top port and large back volume. The figure below shows the frequency response of a number of SiSonic microphones. Each of them is the best fit for a particular application. Having various package choices gives designers more options for microphone placement within the requirements constraints.

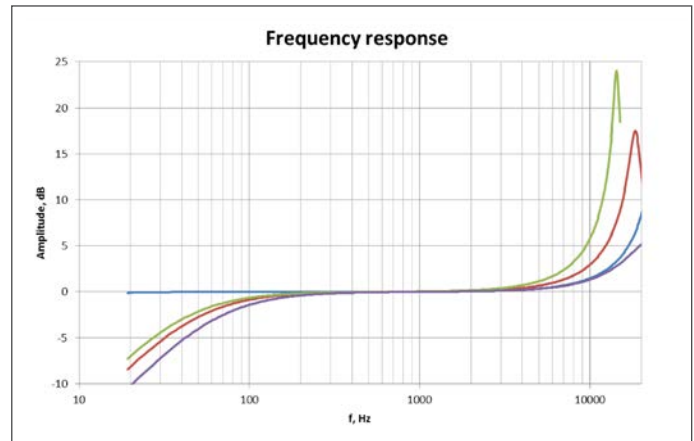

Figure 8: Comparison of the frequency response of various SiSonic package types

ULTRASONIC APPLICATIONS

Bottom-port and MEMS-on-Lid top-port SiSonic microphones inherently have a very usable ultrasonic response from 20 kHz to 80 kHz or more. Selected SiSonic models have additional boost of frequency response in the ultrasonic range. The ultrasonic frequency responses of a regular and ultrasonic boost SiSonic models are shown below.

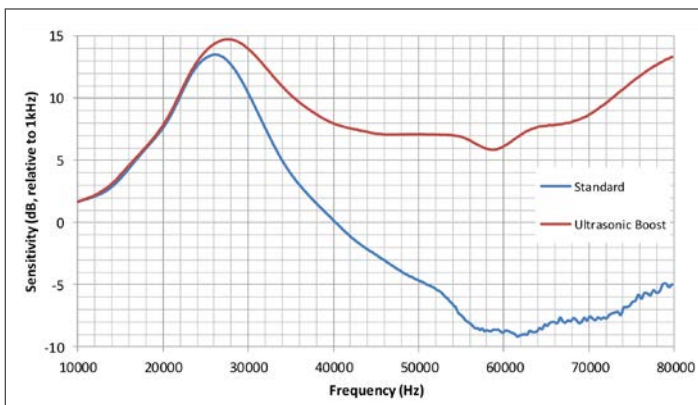

Figure 9: Ultrasonic Frequency Response of SiSonic Microphones

The output of the ultrasonic SiSonic microphone must be processed by an amplifier, codec, or A/D converter that can extract the ultrasonic frequencies needed by the application, usually by using a higher sample rate and/or lower decimation rate. Ultrasonic SiSonic microphones are ideally suited for applications with natural ultrasonic emissions, or for those requiring a separate transmitter and receiver or multiple transmitters at different frequencies.

Potential applications include:

- Consumer Products
- Ultrasonic pen
- Gesture recognition
- Automotive Sensors:
 - Parking assistant
 - Passenger detection
- Burglar systems



CHOOSING THE RIGHT SISONIC MICROPHONE

PACKAGE SIZE

The microphone footprint determines the minimum PCB area required by the mic, and the mic height sets the minimum vertical space required to integrate the mic into a product design. Dimensions of each SiSonic package are shown in the table and figure below.

Package	Port	Length (mm)	Width (mm)	Height (mm)	Footprint (mm ²)	Volume (mm ³)
SPM	Top	4.72	3.76	1.25	17.7	22.0
	Bottom					
SPK	Top	4.00	3.00	1.00	12.0	12.0
	Bottom					
SPG	Bottom	4.00	2.00	0.80	8.0	6.4
SPU	Top	3.76	2.95	1.10	11.1	12.2
	Bottom		3.00		11.3	12.4
SPQ	Top	3.76	2.24	1.10	8.4	9.3
SPH	Top	3.50	2.65	1.0	9.3	9.3
	Bottom			0.98		9.1
SPA	Bottom	3.35	2.50	0.98	8.4	8.2
SPW	Top	3.10	2.50	1.00	7.8	7.8
SPV	Bottom	2.75	1.85	0.90	5.1	4.6

Table 1: SiSonic Packages, Port-Hole Locations, and Dimensions

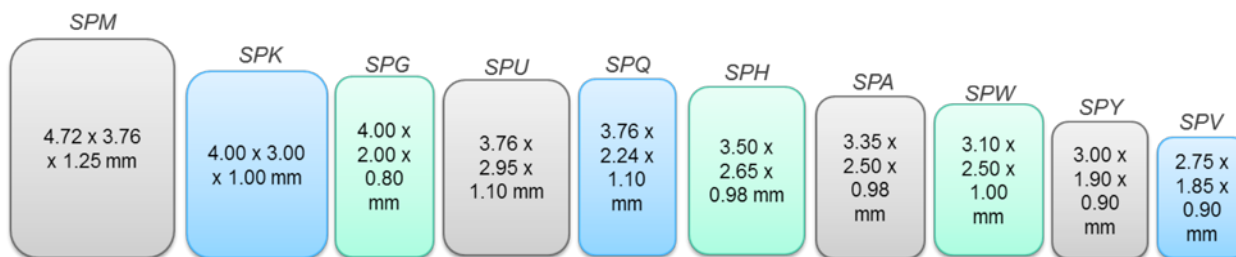

Figure 10: Comparison of SiSonic Package Size

CHOOSING THE RIGHT SISONIC MICROPHONE

OUTPUT FORMAT

Knowles offers wide range of SiSonic MEMS microphone models with electro acoustical characteristics suitable for various applications. The most important acoustic specifications are frequency response, SNR and acoustic overload point (AOP). SNR is defined as the ratio of 1 kHz sensitivity to A-weighted noise in a quiet environment. AOP is the sound pressure level (measured in decibels, dB SPL) at which total harmonic distortion reaches 10 percent. A high AOP microphone should be chosen to work with very loud input signals. This requirement can come from a use case, such as live concert recording, from particularities of system design, such as microphone close proximity to a speaker, or to mitigate the effects of wind noise.



CHOOSING THE RIGHT SISONIC MICROPHONE

From electronic interface perspective, microphones can have different output formats. Each of them has advantages and are described below.

Analog output

Unity-gain SiSonic has a simple buffered output as shown in the figure below. These microphones require codec to digitize to output.

In far-field applications like teleconferencing and video recording, the desired acoustic signal is in the mic far-field and may require additional amplification. Amplified SiSonic microphones add up to 20dB of gain to the analog output signal. Amplifying the signal at the mic versus at the codec improves the overall system (SNR) by increasing the signal size relative to noise and interference in the traces. The amplification in the mic and codec must be chosen appropriately so neither the mic nor codec saturate during operation.

Differential analog SiSonic microphones have better noise immunity. These models have two output pins: Out+ and Out-, each containing half the signal out of phase with each other. The signal on the trace between the microphone and codec is susceptible to interference and noise. These traces should be designed as close to each other as possible to keep the interference equal for both lines. When signals are fed into balanced input of the codec and subtracted from each other the noise contribution will be canceled.

Another advantage to differential output microphones is the output of each output contains only half the signal. The input can then be increased by x2 (6dB). This means AOP is 6dB higher for differential microphones, all other things being equal.

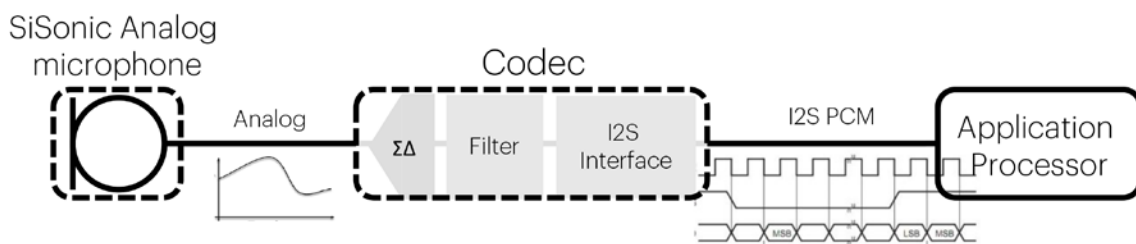

CHOOSING THE RIGHT SISONIC MICROPHONE

PDM Digital SiSonic

Pulse Density Modulated (PDM) Digital SiSonic microphones have a Sigma-Delta Analog to Digital Converter (ADC) integrated into the microphone that accepts a 1.0 MHz to 4.8 MHz clock, and returns over-sampled PDM data at the supplied clock frequency. Decimation and filtering performed by the receiving chipset convert the PDM data stream into the PCM data required by application software. The primary advantage of the digital interface is noise immunity, with secondary benefits of reduced overall system power consumption. Because the mic output is a relatively large digital signal, only extreme noise can cause a bit change, and the half-cycle PDM format used makes the audio data relatively immune to even multi-bit errors. Digital SiSonic microphones are ideal for designs requiring relatively long mic signal traces, especially designs using multiple microphones. Mic traces can be routed to virtually any part of the design with few constraints on routing and a higher probability of success with the first layout, at the same time requiring fewer protective components.

The Select signal configures the microphone to drive the data line when clock value equals high or low. Thus, the DSP should acquire data on the rising edge of the clock for the microphone with grounded Select pin and it should acquire data on the falling edge of the clock signal when the Select pin is tied to Vdd. Two microphones can multiplex data over the same output trace for multi-mic applications, reducing the interface pin count. A basic block diagram of a Digital SiSonic design is shown in Figure 7.

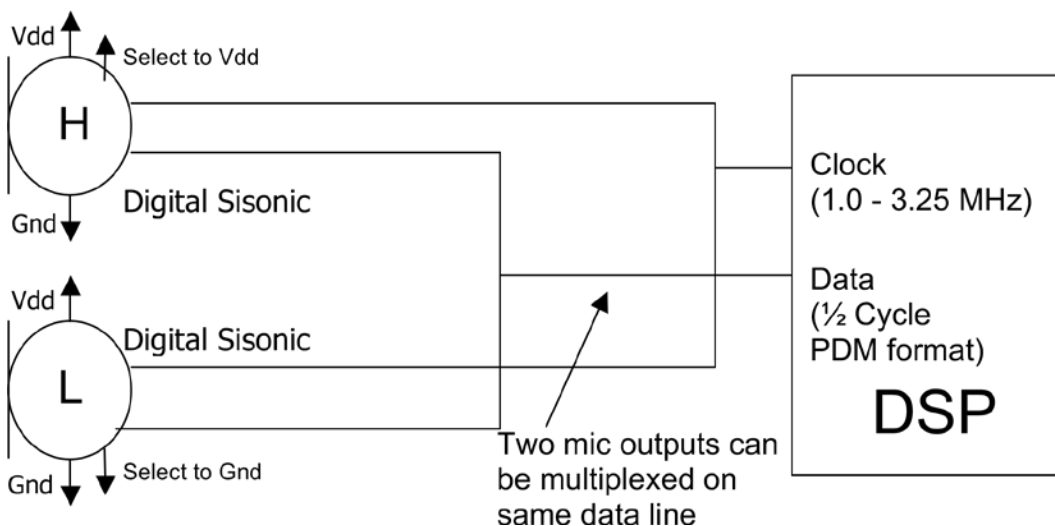
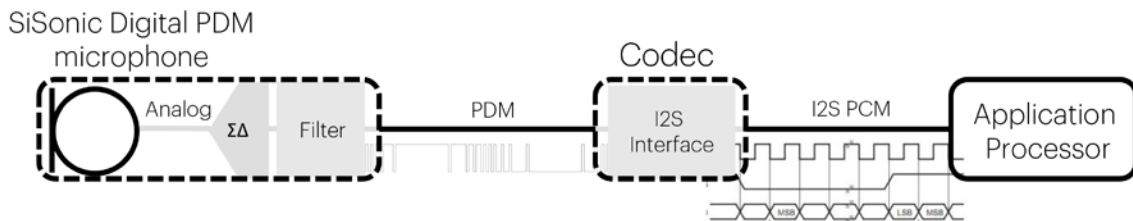

Figure 13: PDM Digital SiSonic Interface

Digital SiSonic microphones require a chipset with a PDM audio interface. Contact Knowles for more information on Digital SiSonic microphones and validated chipset vendors.



CHOOSING THE RIGHT SISONIC MICROPHONE



I2S Digital SiSonic Microphones

I2S Digital SiSonic microphones are easy to integrate since they do not require a codec. Their output can be directly connected to the application processor. These microphones have a decimation filter inside. It operates as an I2S slave with PCM output format. Microphones of this kind are perfect in applications where size and system power consumption is limited. In a manner similar to PDM models, a pair of I2S SiSonic microphones can share a single data and clocks lines when one microphone has SELECT pin grounded and another one has SELECT pin connected to Vdd.

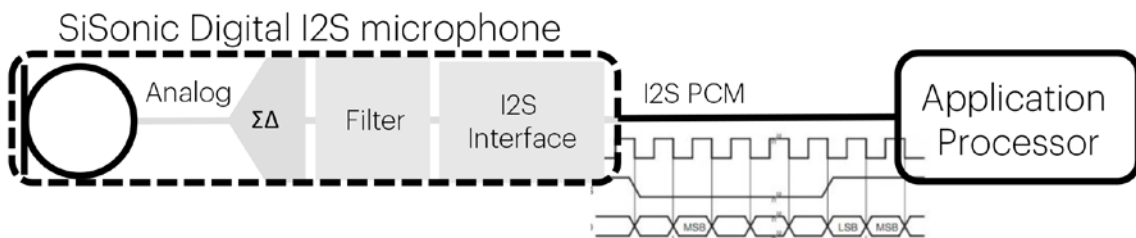

RF PROTECTION LEVEL

SiSonic microphones have integrated RF protection to help prevent RF noise from getting into the acoustic signal. Standard SiSonic microphones have a grounded Faraday cage integrated into the mic package, while other SiSonic models also have RC filters built into the base PCB of the microphone. The best RF performance is achieved with a soldered metal can package and RF filtering built into both the CMOS and the package of the microphone.

SENSITIVITY MATCHING

Knowles complies with very tight tolerances during manufacturing process to ensure a high degree of repeatability in the performance of SiSonic MEMS microphones is achieved. Selected models offer guaranteed matched sensitivity values with part to part variation no more than +/-1 dB. This feature allows use of more aggressive algorithms such as beam forming and noise suppression. Also, tight match of the microphones reduces the range of calibration at the final device level.



CHOOSING THE RIGHT SISONIC MICROPHONE

POWER MANAGEMENT

Power consumption of a microphone can be critical in some applications. For example, small portable devices have limited battery capacity. The approach to current consumption management depends on the type of SiSonic MEMS microphones used. For analog microphones there is not much flexibility. Microphone models with low current consumption specs should be used in order to lower power usage. Digital PDM SiSonic microphones generally have higher current consumption than analog microphones. However, they can have lower overall current consumption at the system level. While choosing between analog and digital microphones one should consider power consumption of corresponding microphones and components that are required to integrate microphones into the system using a certain signal format (codec, ADC, DAC).

Some Digital PDM SiSonic microphone models have several operating modes: sleep mode, low-power mode and performance mode. Operating mode is controlled by the frequency of the clock signal. The ASIC of the microphone detects the clock frequency and can switch modes. At low frequencies, current consumption of the microphone is very low and performance is limited. However, at high frequencies, microphone switches into the performance mode. It reaches the best electroacoustic performance characteristics but also draws more current. Some applications do not require high performance of the microphone all the time and can take advantage of multiple performance modes. When audio quality is not critical the microphone can be in low power or sleep mode and then switched to performance mode as needed.

Operation at faster clock rates often requires the circuit to operate at higher bias currents to charge internal CMOS capacitance. However, at lower clock rates this extra bias current is not required. Some Digital PDM microphones have an additional performance mode power-saving feature that automatically increases/decreases the bias current as the clock rate goes up/down. In this way, current is kept at a minimum, maximizing the available power savings.

Several SiSonic Digital PDM microphone models include automatic voice activity detection (VAD) to implement a Voice Wake feature. With this capability the microphone can be in always-listening mode that does not require an external clock signal. The microphone can identify whether or not there is acoustic signal coming in. The DSP that processes the signal from the microphone can be in deep sleep mode while there is no acoustic activity. This requires very little power. As soon as voice is detected the microphone sends an interrupt to the DSP to wake it up. At that point DSP supplies clock signal to the microphone, switching it into the performance mode, and starts processing high-quality audio. This leads to big power savings, especially when there are multiple microphones integrated in the system. It is enough to have only one Voice Wake always-listening microphone to keep the rest of mics powered down while there is no voice activity. Alternatively, the other microphones can be in low-power mode allowing the availability of beam-forming or other sound enhancement techniques. After an interrupt has been received by the digital signal processor all the microphones can be fully turned on to maximize the performance of the system.



CHOOSING THE RIGHT SISONIC MICROPHONE

MEMS AND ECM MICROPHONES

SiSonic MEMS microphones have a number of advantages over electret condenser microphones (ECM). First, MEMS microphones are surface mounted devices. They can be integrated in an automatic pick and place process and can be reflowed alongside with other components on the PCB. Second, SiSonic microphones provide very stable performance under extreme conditions. They are resistant to power supply noise, mechanical shock and vibration, humidity and moisture condensation. SiSonic microphones have wide operating temperature and supply voltage range where sensitivity does not shift. Finally, performance of SiSonic MEMS microphones is stable over time; sensitivity does not drift.

MULTI-MIC APPLICATIONS

The quality of audio in a cellphone or any other electronic device depends not only on the properties of the microphone but also on the post processing of the signal. The use of multiple microphones in a system provides great opportunities for signal processing and improving sound quality. Integration of additional microphones is justified in multiple use-cases. For example, a pair of microphones in a cellphone allows noise suppression in a close-talk mode and simple beamforming in a far-talk mode. A third microphone provides port occlusion robustness when one of the other port holes is covered with a finger. It also enables advanced beamforming. With four and more microphones it is possible to implement sophisticated algorithms, such as active noise cancellation, and further optimize the performance of a device in a variety of use cases. In general, using multiple microphones and advanced sound processing algorithms leads to completely new and improved user experience.



MECHANICAL DESIGN CONSIDERATIONS



MECHANICAL DESIGN CONSIDERATIONS

The purpose of this section is to provide mechanical design information relating to the microphone including:

- Choosing locations for the mic(s) and acoustic port hole(s) in a customer product's case
- Designing the acoustic path, including gasket design and assembly considerations
- Designing for a wideband frequency response
- Echo prevention and troubleshooting
- Optimizing the land pattern, solder stencil design, and soldering process

CHOOSING THE MIC AND PORT HOLE LOCATIONS

Choosing a location for the microphone in a design can be challenging. For analog mics in particular, the traces from mic to chipset should be kept as short as possible and as far as possible from potential noise sources. However, the layout of many mobile product designs require that the mic and traces be near antennas, power amplifiers, motors, hard disk drives, switching power supplies, etc. The design engineer must also consider the available board space, component height restrictions, port-hole location(s), acoustic path dimensions, and gasket size, location, and ease-of-assembly in mass production when choosing a mic location.

The external acoustic port hole in the product housing should be located near the mic to simplify the gasket and associated mechanical design. The port hole must also be far enough from speakers and other acoustic noise sources to minimize the strength of these unwanted signals at the microphone input. In near-field use modes, like talking normally into a mobile phone, the port-hole location is more critical than in far-field modes since small changes in distance can greatly change the strength of the acoustic signal arriving at the microphone. In both types of applications, the port hole should be located where it won't be blocked during normal use.

If there are multiple mics in a design, then the mic and port-hole locations are further constrained by the related product use-modes and any audio algorithm requirements. Picking good locations for the microphones and port holes early in the design process can prevent costly PCB layout or plastics changes late in the product design cycle.

ACOUSTIC PATH DESIGN

The acoustic path guides external sound into the microphone. The overall frequency response of the microphone in the product design is determined by the standalone microphone frequency response and the physical dimensions of each part of the acoustic path, including the case port hole, gasket(s), and PCB port hole. The acoustic path must not have leaks that can cause multi-path echo or noise problems, and needs to be designed for manufacturability.



MECHANICAL DESIGN CONSIDERATIONS

Acoustic Path Dimensions

A short, wide acoustic path has minimal effects on the mic response while a long, narrow path can create peaks in the audio band, potentially causing a “tinny” sound as higher frequencies are amplified. A good acoustic path design gives a flat sensitivity frequency response across the target frequency range. The designer must measure the total frequency response of the microphone with its acoustic path and make adjustments if the performance doesn’t meet design goals. Possible changes include:

1. A larger case port hole
2. A thinner case at the case port hole
3. A wider gasket cavity
4. A shorter acoustic path from changing the mic or case port hole location
5. A larger and/or thinner PCB hole (for bottom-port mic designs)
6. Adding a screen or mesh as an acoustic resistance to extend the flat frequency response range (see section 3.3)

In addition to the acoustic path, a mesh will also impact the frequency response of a microphone. A mesh over the port hole can be used to protect the microphone from contamination. Any acoustic barrier works as a resistance in the signal path, damping the high frequency resonant peak. The example below shows the effects of a gasket and a mesh on the frequency response of a microphone.

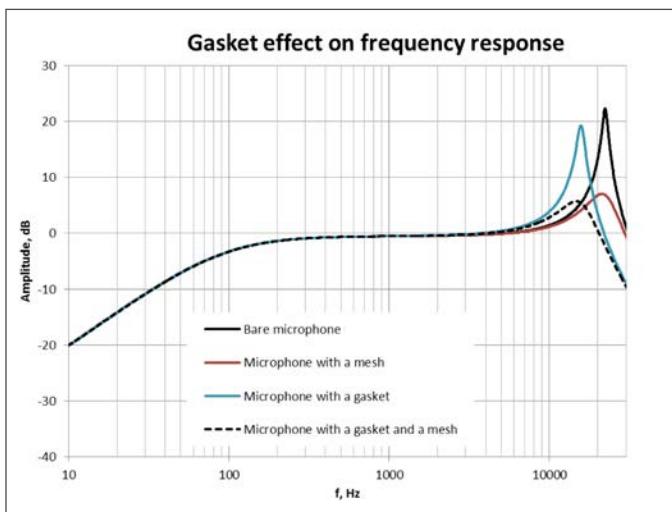

Top-port SiSonic microphones inherently have resonant peak at lower frequency than top-port microphones. The gasket and the mesh can be designed to maintain a wide flat frequency response by attenuating the high-frequency resonance peak. It should provide a short, wide acoustic path from the port hole in the case to the microphone. The gasket port hole should have at least a 0.5mm larger diameter than the microphone port hole to allow for x-y tolerances in the gasket port hole, mic port hole, and gasket placement. At the same time, the gasket port hole must be small enough to ensure a complete seal of the gasket to the mic since any leaks could cause interference noise, and frequency response problems. A simple acoustic path design for a top-port SiSonic microphone is shown below. Case holes and gasket ports can be non-circular, and will generally give similar performance as a circular hole with the same cross-sectional area.

MECHANICAL DESIGN CONSIDERATIONS

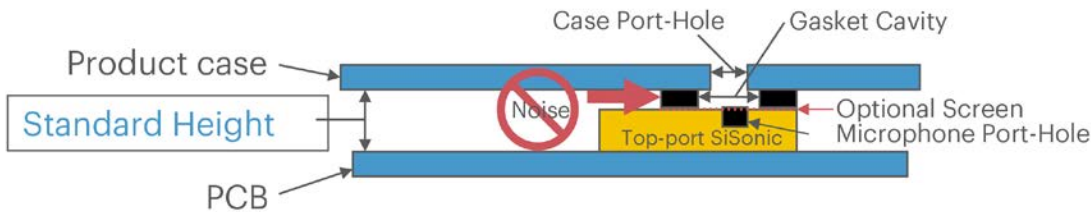

Figure 18: A Simple, Effective Acoustic Path Design for a Top-Port Microphone

For designs using bottom-port SiSonic microphones, the acoustic path also includes the solder ring between the microphone and PCB, and the through-hole in the PCB. The PCB acoustic hole must be large enough to enable alignment with the port hole of the microphone and give a good frequency response. On the other hand, it should be small enough for PCB design rules governing the distance from solder pads to drilled holes. The inside of the PCB acoustic hole must be un-plated so that solder will not wick into the hole and block the hole. A simple acoustic path design for a bottom-port SiSonic microphone is shown below.

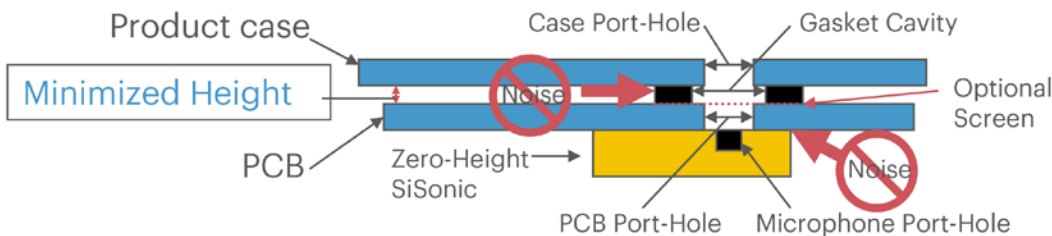

Figure 19: A Simple, Effective Acoustic Path Design for a Bottom-Port Microphone

Gasket Material and Assembly

A gasket must be made of acoustically opaque material that prevents sound from passing through it. Common gasket materials include various kinds of rubber and compressible, closed-cell foams. The material must seal completely to the case and to the microphone or PCB. In a stack-up tolerance analysis, the gasket must form a compression fit in worst case (large gap) conditions, while compressing enough in small gap conditions to avoid bulges in the product case or the walls of the acoustic path. Good acoustic sealing prevents interference noise, and frequency response problems that can result from resonant air volumes inside the product housing and from multiple acoustic paths to the mic porthole.



MECHANICAL DESIGN CONSIDERATIONS

The manufacturability of the mic-gasket-case assembly must also be considered. The assembly process must be designed to reliably align the holes in the gasket to the holes in the case and mic or PCB in volume production. Side-port or end-port gasket designs are more difficult to assemble, since the required gasket compression force is often parallel to the surface of the microphone and perpendicular to the usual case compression force as shown in figure (a) below. These types of gaskets can have problems with leaks during assembly, but a well-designed assembly process or a gasket design, such as that shown in (b), can form good seals.

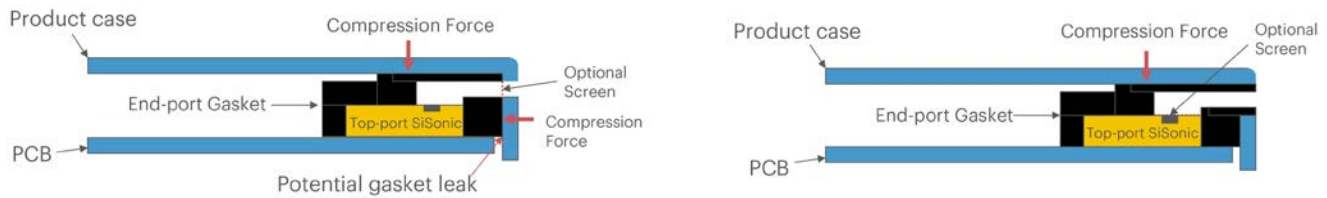

Figure 20: Example of an End-port Gasket Designs

ECHO AND NOISE PROBLEMS

Echo problems are most likely caused by a poor gasket seal. A leak in the gasket seal allows the speaker output or other noise to propagate inside the product case into the mic port, with little loss in strength. An easy way to test for a gasket leak is to block the acoustic port hole in the case. If the echo problem persists, then the echo is likely caused by a gasket leak and can be fixed by a gasket design change. A gasket leak may also cause the microphone to pick up audio noise from other sources, such as a camera zoom motor or a piezoelectric capacitor. The figure below shows a design with a gasket leak.

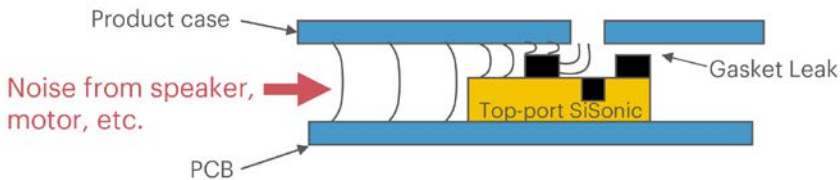

Figure 22: Echo or noise from a gasket leak.



MECHANICAL DESIGN CONSIDERATIONS

In product use modes, such as conference call mode, the speaker output must be strong, so extra care must be taken to prevent echoes. Assuming a good gasket design between the microphone and case, the strength of the speaker output at the microphone input is determined by the shortest path from the speaker to the microphone for sound traveling outside of the product case. The SPL output level of the speaker in open air decreases proportional to $1/R$, and the sound intensity with $1/R^2$. Once again, blocking the case port hole of the product can help determine if this is the source of echoes. If the echo disappears when the case port hole is blocked, then the speaker output signal is too strong for the mic location. An external echo path such as this can be addressed with the following changes:

1. Reduce or limit the speaker output level.
2. Increase the path length from speaker to microphone by changing the location of the microphone and/or speaker in the design until the echo is reduced to an acceptable level.
3. Use echo cancellation software to remove the speaker signal from the mic input.

PCB LAND PATTERN AND SOLDER STENCIL PATTERN

The PCB land pattern, the solder stencil pattern, the solder paste, and the reflow profile should be designed to yield reliable solder joints. The solder joints serve as the electrical connection, mechanical connection, and (for bottom-port mics) the acoustic seal between the mic and PCB. The recommended PCB land pattern for each SiSonic model matches the microphone solder pads dimensions. The solder stencil pattern must be optimized for production, and for bottom-port SiSonic models must use a broken solder ring such as that shown in the figure below.

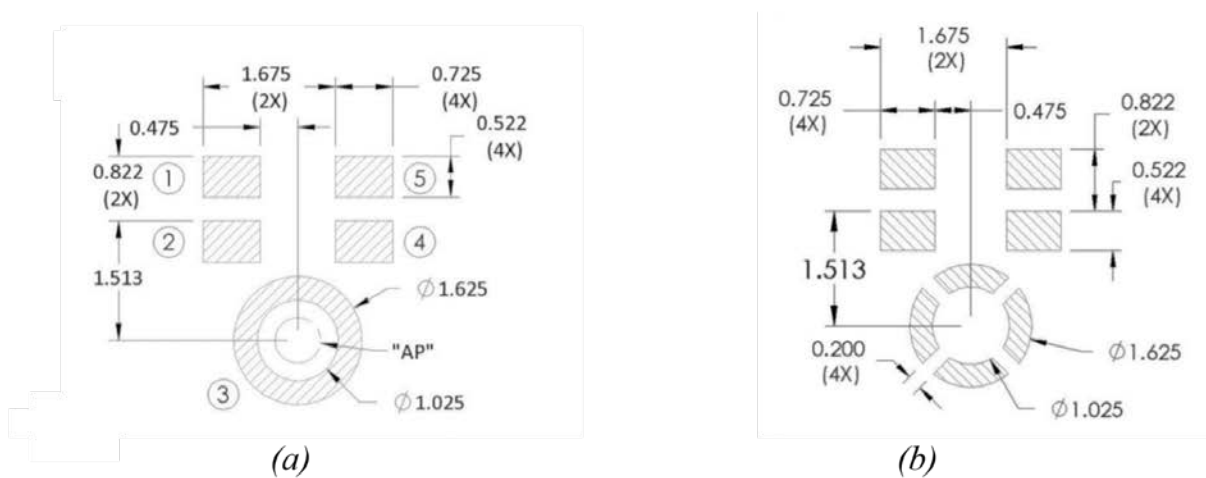

Figure 23: Comparison of SPH SiSonic (a) microphone solder pads and (b) a non-optimized reference solder stencil pattern with a broken solder ring.



MECHANICAL DESIGN CONSIDERATIONS

The solder stencil and land patterns should be designed while considering PCB design rules, solder type, reflow profile, solder stencil thickness, etc. Design optimizations could include:

1. Increasing the land pattern size symmetrically to extend beyond the edge of the mic to allow for visual inspection of the solder joint.
2. Splitting round pads in the land pattern into two semicircles to allow for better out-gassing during reflow and reduce the occurrence of bubbles.
3. For bottom-port mics, reducing the PCB hole diameter or increasing the solder ring diameter to meet PCB design rule requirements.
4. Optimizing the solder reflow profile for each unique board design to ensure good solder joints between the mic and PCB.
5. For bottom-port mics, reducing the solder flux content of solder paste to prevent excessive flux from entering the mic port hole during reflow.
6. Increasing the solder stencil thickness to ensure adequate solder volume for good solder joints.
7. Reducing the solder stencil thickness to reduce solder volume to minimize the occurrence of solder balls.



ELECTRICAL DESIGN CONSIDERATIONS



ELECTRICAL DESIGN CONSIDERATIONS

The interface signals for analog SiSonic microphones include power, output, ground, and sometimes additional signals. Since analog microphones have small amplitude outputs that are susceptible to noise, care should be taken with the trace routing to avoid potential noise problems. This section outlines recommendations for interfacing to each SiSonic signal, with an emphasis on the interface between the microphone output and the codec or chipset.

POWER SUPPLY

SiSonic microphones have no change in sensitivity with supply voltage, so the system designer only needs ensure that the supply voltage stays in the specified range, typically 1.5 to 3.6V. Because SiSonic microphones have a separate power supply line and an internal voltage regulator, it is less susceptible to power supply noise than traditional ECMs. The Power Supply Rejection Ratio (PSRR) for SiSonic microphones is typically 60dB, but even with this level of PSRR strong power supply noise can cause significant noise in the microphone output. For example, a 10mV RMS noise signal attenuated by 60dB still results in a 10 μ V RMS ripple in the microphone output. This can be significant compared to the 5 μ V RMS typical noise floor of the microphone, and is equivalent to an acoustic input of about 36dB SPL. If there is strong noise in the microphone power supply, then bypass capacitors may be added to stabilize the supply as shown in Figure 28.

GROUND

All microphone ground pads should be connected to a quiet analog ground plane through a short, wide trace that is not daisy-chained from device to device. If there is strong noise in the ground plane, some designs may benefit from a series ferrite bead or inductor in the ground path to isolate the microphone from the noise. Amplified SiSonic models are designed to be drop-in replacements for non-amplified models of the same package size, with one ground pad changed to be the gain control pad. If it is anticipated that an amplified mic output may be needed in a design, the gain control pad can be connected to ground through appropriate components to set the desired gain (see the next section.) If non-amplified SiSonic microphones are used in the final design, then the gain pad components can be left unpopulated and the pad will be grounded internally by the non-amplified mic.



ELECTRICAL DESIGN CONSIDERATIONS

GAIN CONTROL

The gain of amplified SiSonic microphones is set using a resistor and capacitor connected to the Gain Control terminal of the microphone, as shown in the circuit below.

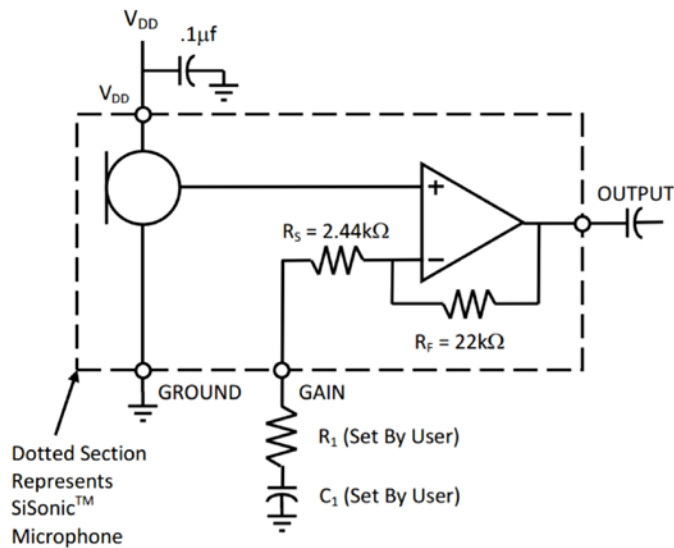

Figure 24: Gain control circuitry for amplified SiSonic

The value of R3 is chosen to give the desired gain value, with a maximum gain of 20dB when R3 is 0Ω. C1 allows proper DC biasing of the amp input, and should be chosen so that the corner frequency of the high-pass filter formed by C1, R2, and R3 is well below the acoustic range. If no additional gain is required, the Gain Control terminal can be tied directly to the output terminal for the same sensitivity as a non-amplified SiSonic. The gain terminal should not be left floating since this terminal is susceptible to noise. R3 and C1 are calculated using the following formulas:

Setting Gain Formulas:
Gain is determined as:
 $G = 1 + \{R1 / (R2 + R3)\}$ Gain (dB) = 20 * log(G)
High-pass filter Corner Frequency:
 $1 / \{2\pi * (R2 + R3) * C1\}$

Figure 25: Formulas for calculating gain control component values

The R and C components should be located as near to the microphone as possible, since any noise picked up in the Gain Control terminal would also get amplified.



ELECTRICAL DESIGN CONSIDERATIONS

MICROPHONE TO CODEC INTERFACE CIRCUIT

The interface circuit between an analog SiSonic microphone output and the codec or baseband chipset can be very simple depending on the design needs. If the codec input is self-biasing, then the only interface component required is a coupling capacitor. This capacitor forms a high pass filter with the input impedance of the codec or chipset, so is typically in the μF range for a 3dB point $<100\text{Hz}$. It should be positioned as close as possible to the codec. Some chipsets require an external DC bias circuit after the coupling capacitor, and chipset documentation should be consulted for the recommended audio interface circuit. Unlike ECMs, SiSonic microphones do not need a resistor from the output to power since they have a separate power terminal and a built-in voltage regulator.

In general, the output trace should be kept as short as possible, and should be routed over or between analog ground planes to shield it from noise. The figure below shows a simple microphone interface circuit.

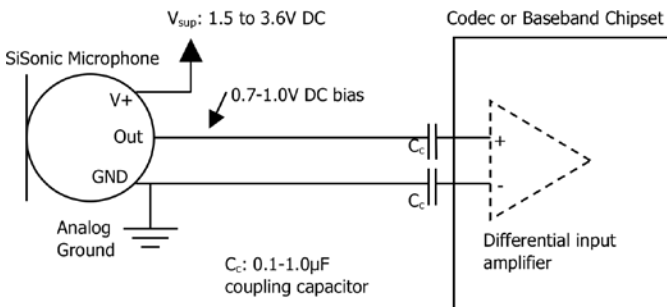

Figure 26: Example of a simple SiSonic interface circuit

SISONIC 2-WIRE CIRCUIT

Analog SiSonic microphones require a 3-wire interface, but for some applications like headsets a 2-wire interface is needed to reduce the number of conductors running through a cable. Most of the analog SiSonic models can be used in 2-wire mode. The 2-wire circuit shown in the figure below uses a load circuit on the mic output node to generate an AC current in the power node, which becomes the output of the 2-wire circuit. The output is converted into a voltage when the current flows through the load resistor connected to the 2-wire output.



ELECTRICAL DESIGN CONSIDERATIONS

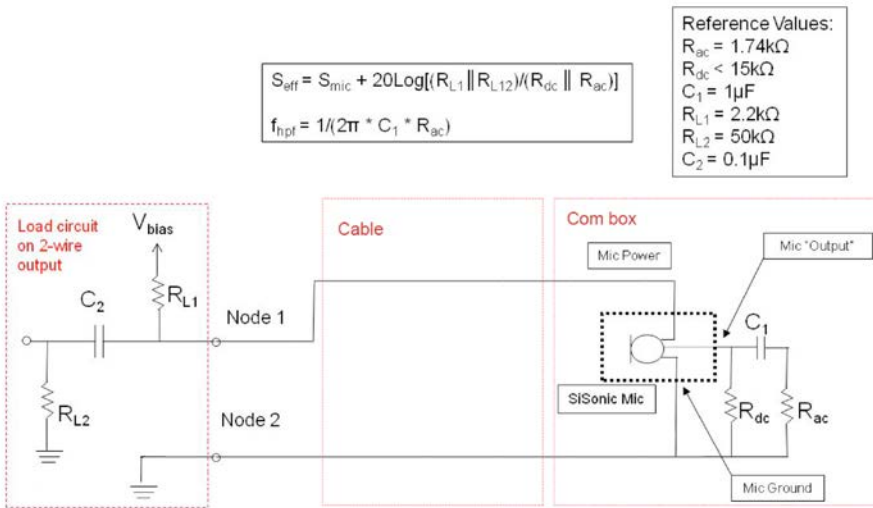

Figure 27: Circuit for 2-wire SiSonic microphone interface.

MINIMIZING NOISE PICK-UP

Many product designs, like tablets and mobile handsets, require the microphone(s) to be near noise sources, like antennas and power amplifiers. RF signals are not themselves a problem since they are well above audio frequencies, but many wireless standards use TDMA technologies where data is sent in bursts or packets. The frequency of these packets usually falls in the audio range and can induce an undesirable “buzz” in the audio signal.



ELECTRICAL DESIGN CONSIDERATIONS

In designs where noise is a concern, there are a number of techniques a designer can use to protect the audio signal from noise, including:

1. Keep signal traces as far as possible from potential noise sources.
2. Route traces on inner PCB layers protected by ground layers, and keep trace lengths as short as possible.
3. Surround the microphone package with a ground plane if possible.
4. Add capacitor(s) between the microphone power and ground to help remove power supply noise.
5. Use series ferrite beads (chokes), inductors, and RF shunt capacitors to reduce RF noise in traces. Place ferrite beads near the mic or where traces come out from middle PCB layers, and place caps on the chipset side of the ferrite beads.
6. DO NOT route the output and Vdd signals in parallel with no ground between, as this could ruin cross-talk performance.
7. Use Digital SiSonic to minimize noise picked up by the output traces.
8. Configure single-ended SiSonic differentially by using the output and ground as the two sides of a differential pair. Use a series resistor on the ground line to balance the pair. The value should be equal the output impedance of the microphone.
9. Place the microphone and associated circuitry in shielded areas of the design to reduce the potential for RFI and EMI pick-up.

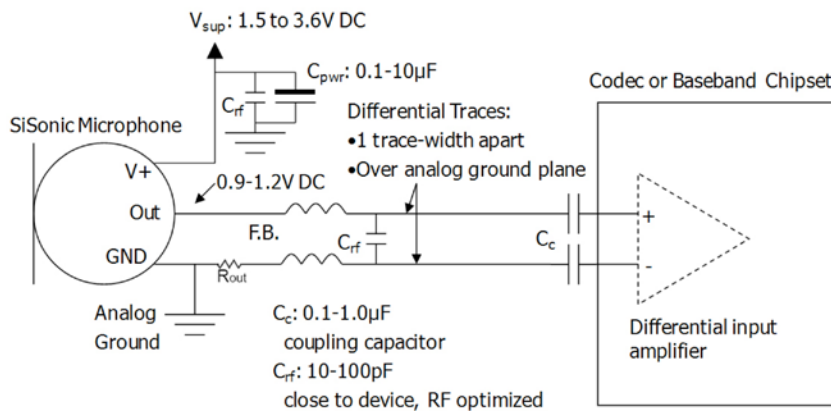

Figure 28: Single-ended SiSonic design with noise protection techniques



MANUFACTURING INFORMATION



MANUFACTURING INFORMATION

SiSonic microphones are surface mount microphones intended for installation with standard pick-and-place machinery for reflow onto a PCB with other surface mount components. Because SiSonic microphones are electro-acoustic components, they have some unique requirements in an automated assembly line.

PICK-AND-PLACE SETTINGS

SiSonic microphones come in various size reels for use in auto pick-and-place machines. The pick location for top-port models must be chosen so the pick nozzle does not overlap the port hole of the microphone, while taking into account the microphone and pocket tolerances and the pick nozzle shape, size, and placement accuracy. Bottom-port models may be picked anywhere on the lid. The recommended pick area for the SPW package is shown in the figure below. Exact packaging information, including pocket size, spacing and pick-and-place area, is shown in each model's datasheet.

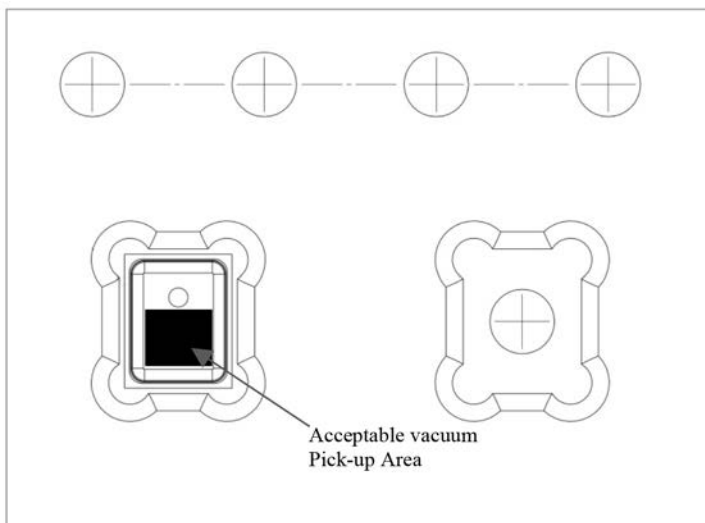

Figure 29: SiSonic Pick Area.

MANUFACTURING INFORMATION

REFLOW

SiSonic microphones have gold-plated solder pads designed for use with lead-free solders. The recommended solder stencil thickness range is 0.127 mm to 0.178 mm. SiSonic is guaranteed for up to 3x passes through a lead-free solder reflow profile, and manufacturing line samples are tested weekly with 5x reflows at the maximum profile conditions as part of On going Reliability Tests (ORTs). The exact reflow profile should be optimized for each design, but should not exceed the maximum reflow profile for the microphone shown below (based on IPC/JDEC J-STD-020 Rev C):

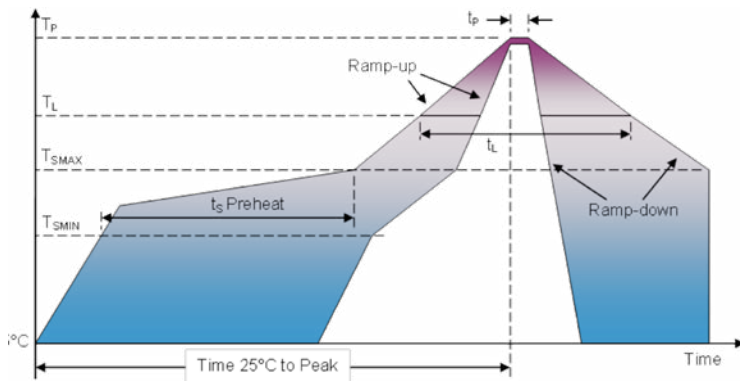

Figure 31: SiSonic maximum solder reflow profile

Profile Feature	Pb-Free
Average Ramp-up rate (TSMAX to TP)	3°C/second max.
Preheat •Temperature Min (TSMIN) •Temperature Max (TSMAX) •Time (TSMIN to TSMAX) (tS)	150°C 200°C 60-180 seconds
Time maintained above: •Temperature (TL) •Time (tL)	217°C 60-150 seconds
Peak Temperature (TP)	260°C
Time within 5°C of actual Peak Temperature (tP)	20-40 seconds
Ramp-down rate (TP to TSMAX)	6°C/second max
Time 25°C to Peak Temperature	8 minutes max

REWORK

Rework of SiSonic microphones is recommended using a temperature-ramp controlled system such as an A.P.E. Chipper. The local area around the microphone can be heated until solder reflow allows the microphone to be removed with a vacuum nozzle or tweezers. Installation of a new microphone component is recommended using the same reflow profile used to install the original component.



MANUFACTURING INFORMATION

HANDLING AND STORAGE

SiSonic microphones are installed using solder reflow processes. As a result, the downstream processes in the production line must be reviewed to ensure that they do not damage the microphone. Information on handling and storage for SiSonic microphones is listed below:

1. Ingress protection. Make sure to minimize the risk of any contamination ingress through the port hole of the microphone.
2. Shelf life: Twelve (12) months when devices are to be stored in factory supplied, unopened ESD moisture sensitive bag under maximum environmental conditions of 30°C, 70% R.H.
3. MSL (moisture sensitivity level) Class 1.
4. Do not pull a vacuum over port hole of the microphone. Pulling a vacuum over the port hole can damage the device.
5. Do not board wash after the reflow process. Board washing and cleaning agents can damage the device. Do not expose to ultrasonic processing or cleaning.
6. Do not brush board after the reflow process. Brushing the board with/without solvents can damage the device.
7. Do not insert any object in port hole of device at any time as this can damage the device.
8. Number of reflows - Recommend no more than 3 cycles.
9. Do not vacuum seal static bags used to store unused portions of reels.
10. Do not directly expose to ultrasonic processing, welding, or cleaning.
11. Do not apply over 30 psi of air pressure into the port hole.

QUALIFICATION TESTING

SiSonic microphones are lead-free compliant and are certified Sony Green, and all Knowles facilities are ISO certified. SiSonic microphones also undergo a regular battery of Ongoing Reliability Tests (ORTs) to ensure consistent quality microphones. Additional qualification testing is performed on all new designs to verify that the performance and quality of each microphone is maintained. These additional tests are outlined in the table below:



MANUFACTURING INFORMATION

Test	Description
Thermal Shock	100 cycles of air-air thermal shock from -40°C to +125°C with 15min soaks. (ICE 68-2-4)
High Temperature Storage	+105°C environment for 1,000 hours. (IEC 68-2-2 Test Ba)
Low Temperature Storage	-40°C environment for 1,000 hours. (IEC 68-2-1 Test Aa)
High Temperature Bias	+105°C environment while under bias for 1,000 hours. (IEC 68-2-2 Test Ba)
Low Temperature Bias	-40°C environment while under bias for 1,000 hours. (IEC 68-2-1 Test Aa)
Temperature / Humidity Bias	+85°C/85% RH environment while under bias for 1,000 hours. (JESD22-A101A-B)
Vibration	16 minutes in each X, Y, and Z direction from 20 to 2,000Hz with peak acceleration of 20 G. (MIL 883E, Method 2007.2, A)
ESD-HBM	3 discharges at +/- 2kV direct contact to the I/O pins (MIL 883E, Method 3015.7)
ESD-LID/GND	3 discharges at +/- 8kV direct contact to the lid when unit is grounded (IEC 61000-4-2)
ESD-MM	3 discharges at +/- 200V direct contact to the I/O pins (MIL 883E, Method 3015.7)
Reflow	5 reflow cycles with peak temperature of +260°C.
Mechanical Shock	3 pulses of 10,000g in the X, Y, and Z direction. (IEC 68-2-27, Test Ea)

Table 6: SiSonic Qualification Tests

SENSITIVITY MEASUREMENTS

Accurate sensitivity measurements should be made in an anechoic chamber, where an acoustic signal from a speaker is captured by the test microphone in a noise-free environment and a reference microphone is used to calibrate out any non-linearities of the speaker and chamber.

The Microphone Evaluation Kit KAS-33100-002 is available from Digikey for quick measurements of individual microphones. Using the kit, it is possible to connect a pair of analog, digital or I2S SiSonic microphones to a computer via USB for signal processing or connected directly to speakers or headphones. See knowles.com for more information.





REVISIONS

Revision 1	11/15/17

ADDITIONAL RESOURCES

For more information on SiSonic microphones, see the Knowles web site at www.knowles.com.

KNOWLES CORPORATION
1151 Maplewood Drive Itasca, IL 60143, USA
Phone: 1-630-250-5100

