

CI-28417-A42

SHT 1.1

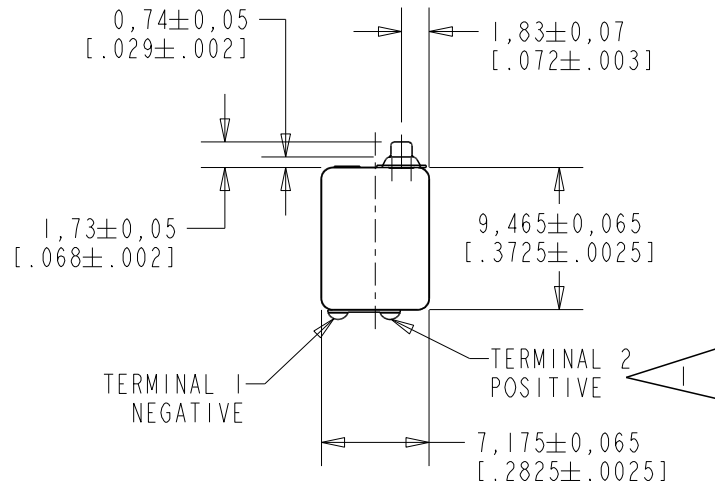

NOTES:

▲ A POSITIVE GOING VOLTAGE AT TERMINAL 2, RELATIVE TO TERMINAL 1, CAUSES A DECREASE IN PRESSURE AT THE SOUND OUTLET.

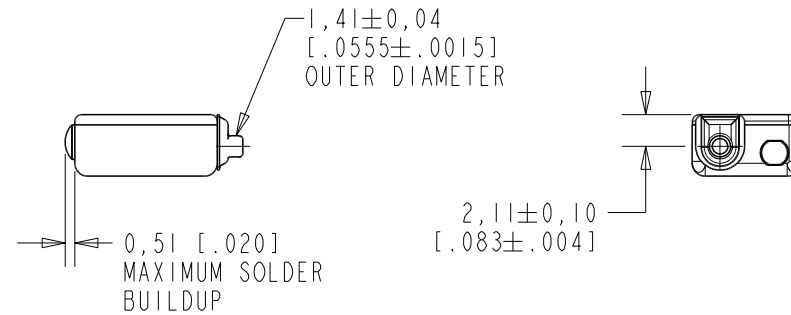
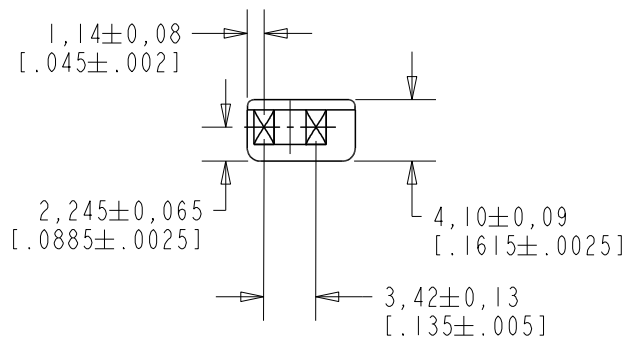

NOMINAL WEIGHT  
1.0 GRAM

DIMENSIONS IN MILLIMETERS [INCHES]

Revision	C.O. #	Implementation Date	RELEASE LEVEL	REVISION
			Active	D
D	PI0000944	11-8-16		

SCALE: 2:1

DR. BY DATE

DMS 11-30-05

CK. BY DATE

GJP 12-5-05

APP. BY DATE

GJP 12-5-05

**KNOWLES CORPORATION**

TITLE: RECEIVER

CI-28417-A42

OUTLINE DRAWING

SHT 1.1

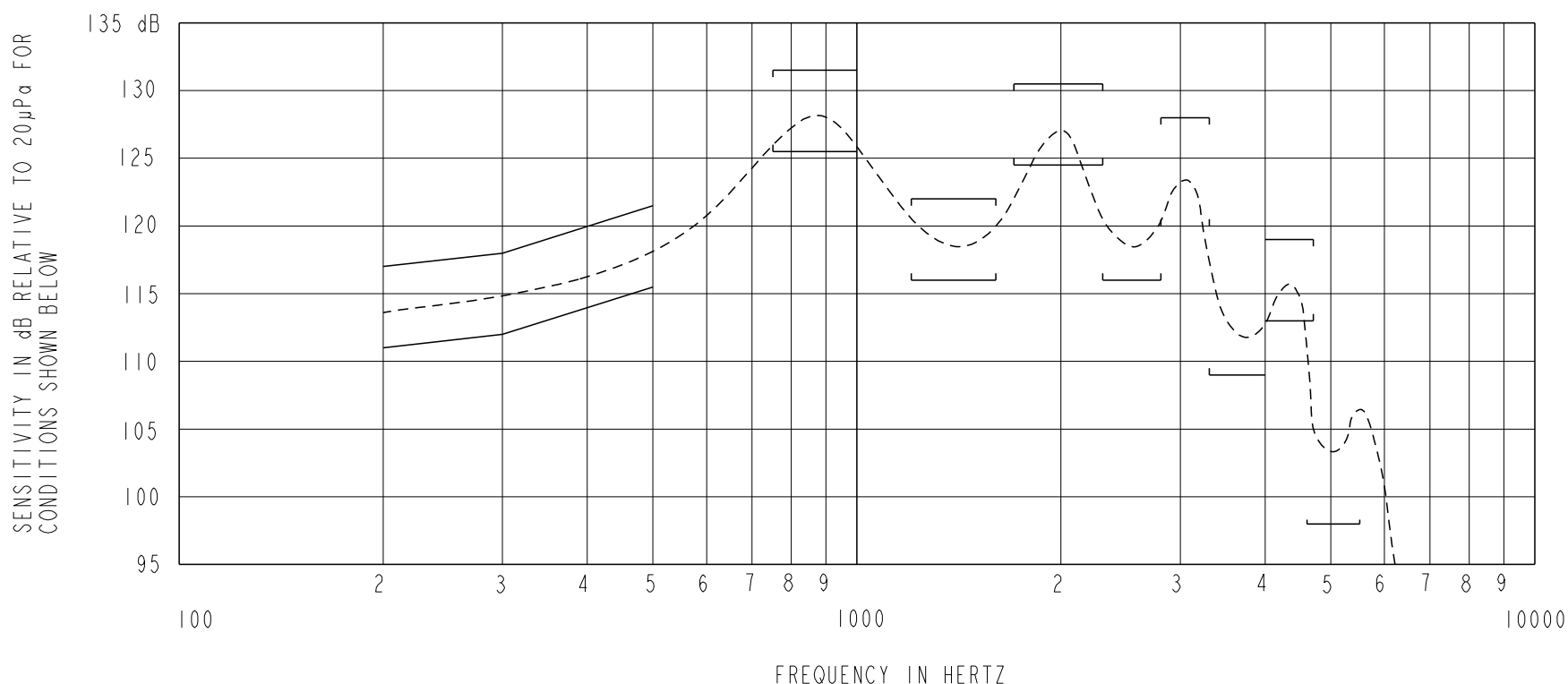

NOTES:

1. MEASUREMENTS MADE USING 8mm [.315"] X 1mm [.039"] ID + 28mm [1.10 ] X 1.5mm [.059 ] ID EAR HOOK SIMULATOR INTO 25mm [.984"] OF 2mm [.079"] ID TUBE + 18mm [.709"] OF 3mm [.118"] ID TUBE + 2 CM<sup>3</sup> CAVITY ANSI S3.6 TYPE HA-3 (IEC 60318-5).

2. SENSITIVITY

FREQUENCY	MIN.	MAX.
200	111.0	117.0
300	112.0	118.0
500	115.5	121.5
750-1000	125.5	131.5
1200-1600	116.0	122.0
1700-2300	124.5	130.5
2300-2800	116.0	---
2800-3300	120.0	128.0
3300-4000	109.0	---
4000-4700	113.0	119.0
4600-5500	98.0	---

3. RESPONSE, IMPEDANCE, AND DISTORTION MEASUREMENTS MADE USING THE ELECTRICAL TEST CONDITIONS SHOWN BELOW.

4. INDIVIDUAL SPECIFICATIONS.

PORT LOCATION	ELECTRICAL TEST CONDITIONS				IMPEDANCE @ 500 Hz OHMS ± 20%	DCR @ 20°C OHMS ± 10%	DISTORTION	
	RESPONSE & IMPEDANCE		DISTORTION				MAX. %	FREQ. Hz
	AC mA RMS	DC mA	AC mA RMS	DC mA				
IS	3.75	0.0	7.5	0.0	47	20	10	500

5. ELECTRICAL SOURCE IMPEDANCE MUST BE GREATER THAN 20 TIMES STATED IMPEDANCE FOR TEST CONDITIONS ABOVE.

6. SUFFIX DESCRIPTION:  
MANUFACTURE CI UNITS WITH MINIMUM SOLDER COVERAGE ON TERMINAL PADS.  
MAX. HEIGHT (CASE TO TOP OF SOLDER) 0.020" [0.5mm].

Revision	C.O. #	Implementation Date	RELEASE LEVEL	REVISION
			Active	D
D	PI0000944	11-8-16		
WHEN TEST LIMITS ARE USED TO ESTABLISH INCOMING INSPECTION ACCEPTANCE/REJECTION CRITERIA, CORRELATION OF TEST EQUIPMENT WITH KNOWLES IS ALSO REQUIRED FOR ELIMINATION OF EQUIPMENT AND TEST METHOD VARIATION				
TITLE: RECEIVER			CI-28417-A42	DR. BY DATE DMS 11-30-05
PERFORMANCE SPECIFICATION			SHT 2.1	CK. BY DATE GJP 12-5-05
				APP. BY DATE GJP 12-5-05

**KNOWLES CORPORATION**