

FED-26729-106

SHT 1.1

NOTE:

- 1 A POSITIVE GOING VOLTAGE AT TERMINAL 2, RELATIVE TO TERMINAL 1, CAUSES A DECREASE IN PRESSURE AT THE SOUND OUTLET.
- 2 LOCATED FROM TWO SURFACES FOR CUSTOMER CONVENIENCE. ONLY APPLICABLE FROM ONE SURFACE, NOT TO BE USED TOGETHER. HORIZONTAL LOCATION FOR TERMINAL CENTERED TO $\pm 0,17$ [.007].

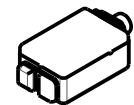
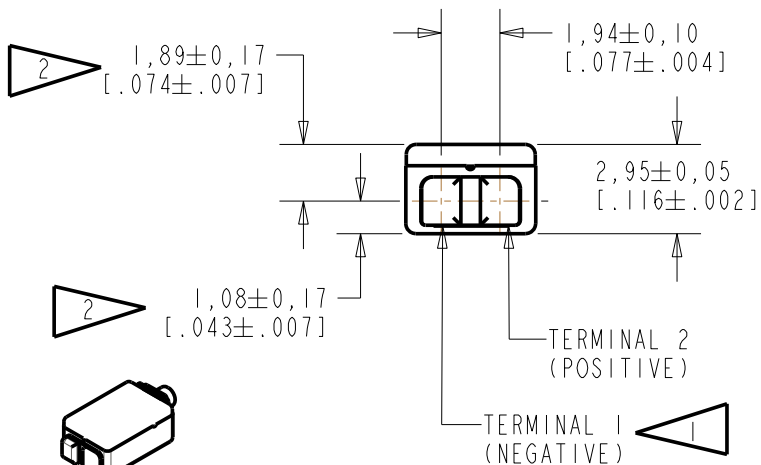
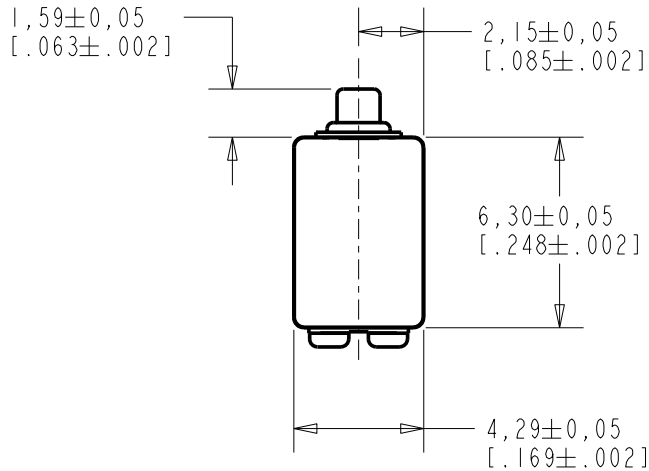

SCALE 2:1

NOMINAL WEIGHT
.31 GRAMS

DIMENSIONS IN MILLIMETERS [INCHES]

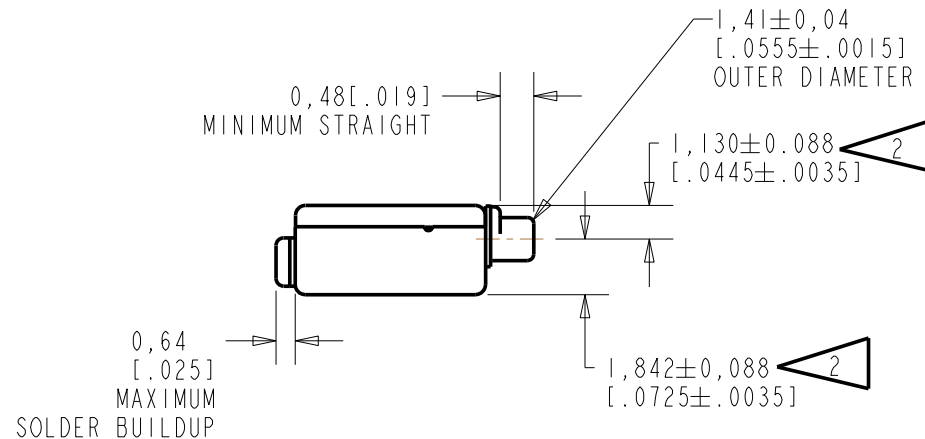

Revision	C.O. #	Implementation Date	RELEASE LEVEL	REVISION
B	C10107990	11-20-08	Active	B
A	C10103596	1-31-06		

SCALE:	4:1	DR. BY	DATE
DO NOT SCALE DRAWING		CRG	1-31-06
TITLE:	RECEIVER	GJP	2-8-06
	OUTLINE DRAWING	APP. BY	DATE
		GJP	2-8-06

KNOWLES ELECTRONICS
ITASCA, ILLINOIS U.S.A.

FED-26729-106

SHT 1.1

CONSTANT VOLTAGE DRIVE CONDITIONS

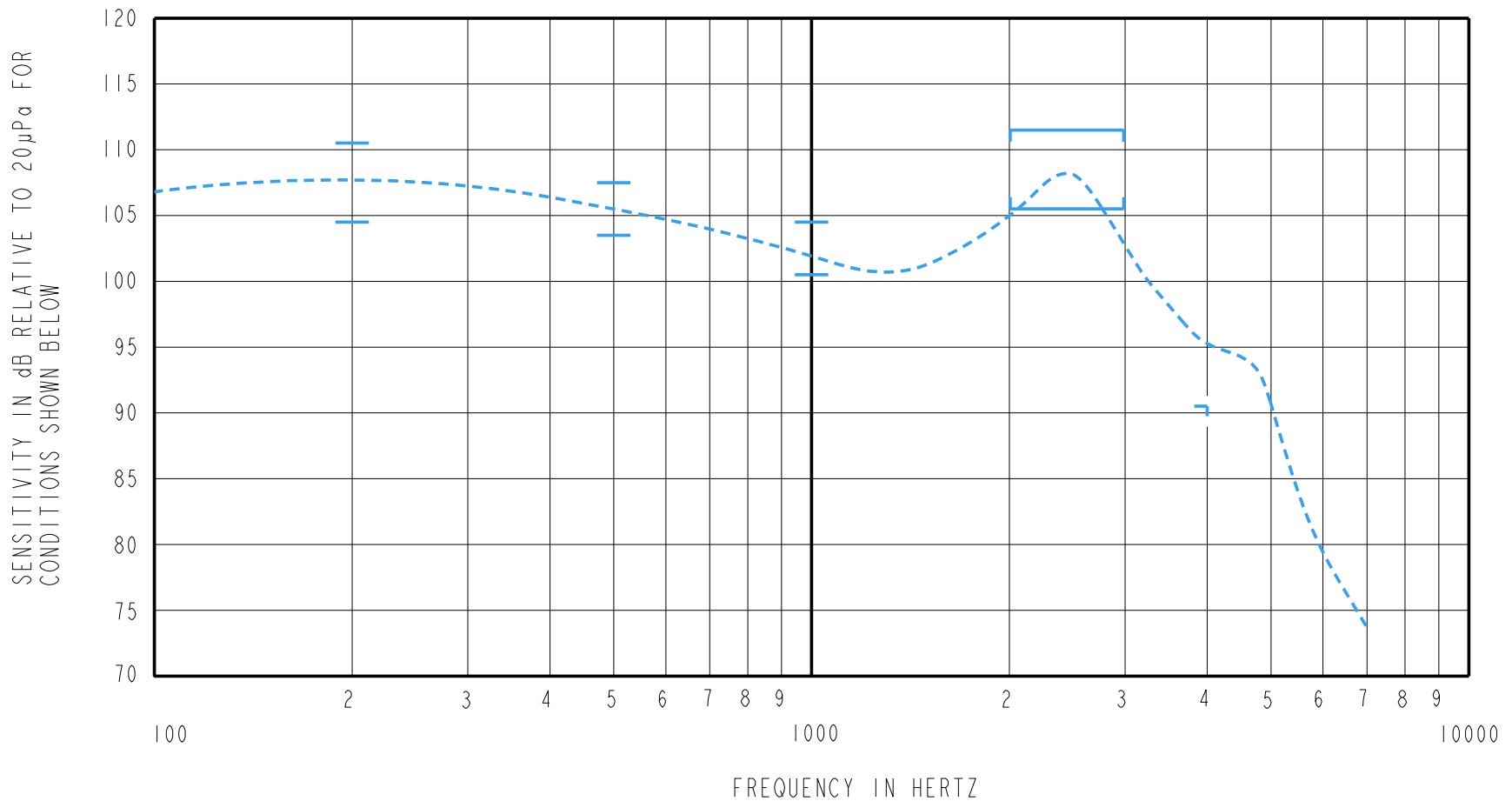

ACOUSTICAL

SENSITIVITY
DEVICE WILL PRODUCE THE SPL LISTED BELOW UNDER TEST CONDITIONS DESCRIBED IN TABLE 3.
NOMINAL SENSITIVITY AT 1kHz IS dB RELATIVE TO 20µPa. ALL OTHER VALUES
IN dB RELATIVE TO THE SENSITIVITY AT 1kHz.

FREQUENCY (Hz)	MINIMUM	NOMINAL	MAXIMUM
200	+2.0	+5.0	+8.5
500	+1.0	+3.0	+5.0
1000	-2.0	102.5	+2.0
2000 - 3000	+3.0	+6.0	+9.0
4000	-12.0	---	---

PORT LOCATION: 12C

TABLE 1

TOTAL HARMONIC DISTORTION
DEVICE WILL NOT EXCEED TOTAL HARMONIC DISTORTION LEVELS LISTED BELOW.

FREQUENCY (Hz)	AC DRIVE (V rms)	DC BIAS (mA)	LIMIT (%)
500	1.203	0	10
830	0.427	0	5
1250	0.427	0	5

TABLE 2

TEST CONDITIONS

NOMINAL SOURCE VOLTAGE	0.427 V rms, 0mA DC BIAS
SOURCE IMPEDANCE	<1 Ohm
TUBING	10mm [.394"] LONG, 1mm [.039"] I.D.
COUPLER CAVITY	2 CM ³ , SIMULATED ANSI S3.7 TYPE HA-3 (IEC 126)

TABLE 3

ELECTRICAL

DC RESISTANCE	196 OHMS ± 10%
IMPEDANCE @ 500 Hz	390 OHMS ± 15%
IMPEDANCE @ 1 kHz	690 OHMS ± 15%

TABLE 4

ISOLATION: CASE WILL BE ELECTRICALLY ISOLATED FROM THE COIL CIRCUIT.

TEMPERATURE: OPERATING RANGE FROM 0°C TO 63°C (SENSITIVITY WILL NOT VARY BY MORE THAN ±3 dB WITHIN RANGE)
SENSITIVITY AT 0°C IS 2dB LOWER THAN THE SENSITIVITY AT ROOM TEMPERATURE.
DELTA PEAK IS 1dB HIGHER AT BODY TEMPERATURE (37°C)
STORAGE RANGE FROM -40°C TO 63°C.

Revision	C.O. #	Implementation Date	RELEASE LEVEL	REVISION
B	C10107990	11-20-08	Active	B
A	C10103596	1-31-06		
WHEN TEST LIMITS ARE USED TO ESTABLISH INCOMING INSPECTION ACCEPTANCE/REJECTION CRITERIA, CORRELATION OF TEST EQUIPMENT WITH KNOWLES IS ALSO REQUIRED FOR ELIMINATION OF EQUIPMENT AND TEST METHOD VARIATION				
TITLE: RECEIVER		FED-26729-106		DR. BY DATE
PERFORMANCE SPECIFICATION		SHT 2.1		CRG 1-31-06
				CK. BY DATE
				GJP 2-8-06
				APP. BY DATE
				GJP 2-8-06

KNOWLES ELECTRONICS
ITASCA, ILLINOIS U.S.A.