

TM-24546-C36
SHT 1.1

NOTES:

- INCREASED PRESSURE AT SOUND INLET CAUSES A POSITIVE GOING VOLTAGE TO APPEAR AT THE OUTPUT TERMINAL, RELATIVE TO THE NEGATIVE TERMINAL.

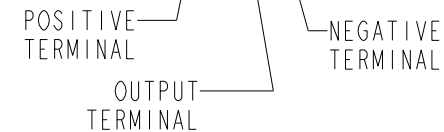
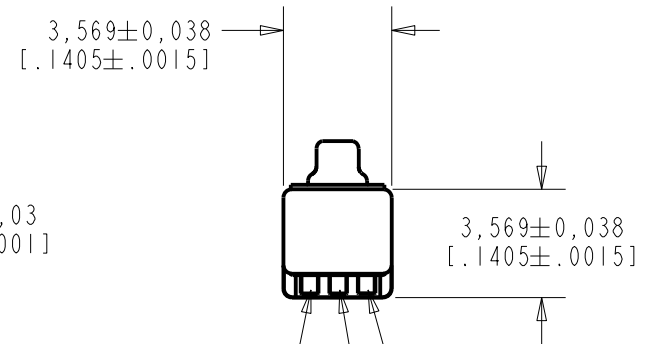
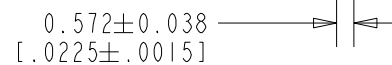
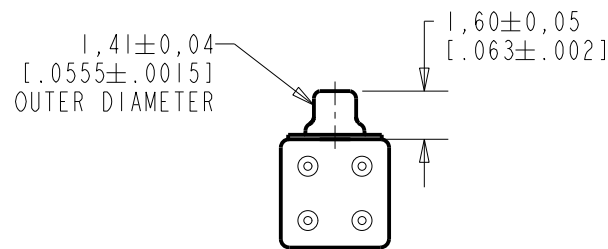
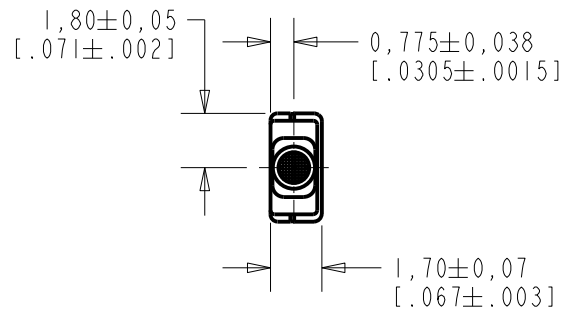

NOMINAL WEIGHT
.08 GRAMS

DIMENSIONS IN MILLIMETERS [INCHES]

Revision	C.O. #	Implementation Date	RELEASE LEVEL	REVISION
			Active	G
G	MI0105774	10-31-14		

SCALE: **4:1**

DO NOT SCALE DRAWING

TITLE:	MICROPHONE	TM-24546-C36
	OUTLINE DRAWING	SHT 1.1

DR. BY	DATE
MMM	1-4-06
CK. BY	DATE
GJP	1-5-06
APP. BY	DATE
GJP	1-5-06

KNOWLES ELECTRONICS
ITASCA, ILLINOIS U.S.A.

SENSITIVITY IN dB RELATIVE TO 1.0 VOLT/0.1 Pa (N/M²)
FOR CONDITIONS SHOWN BELOW.

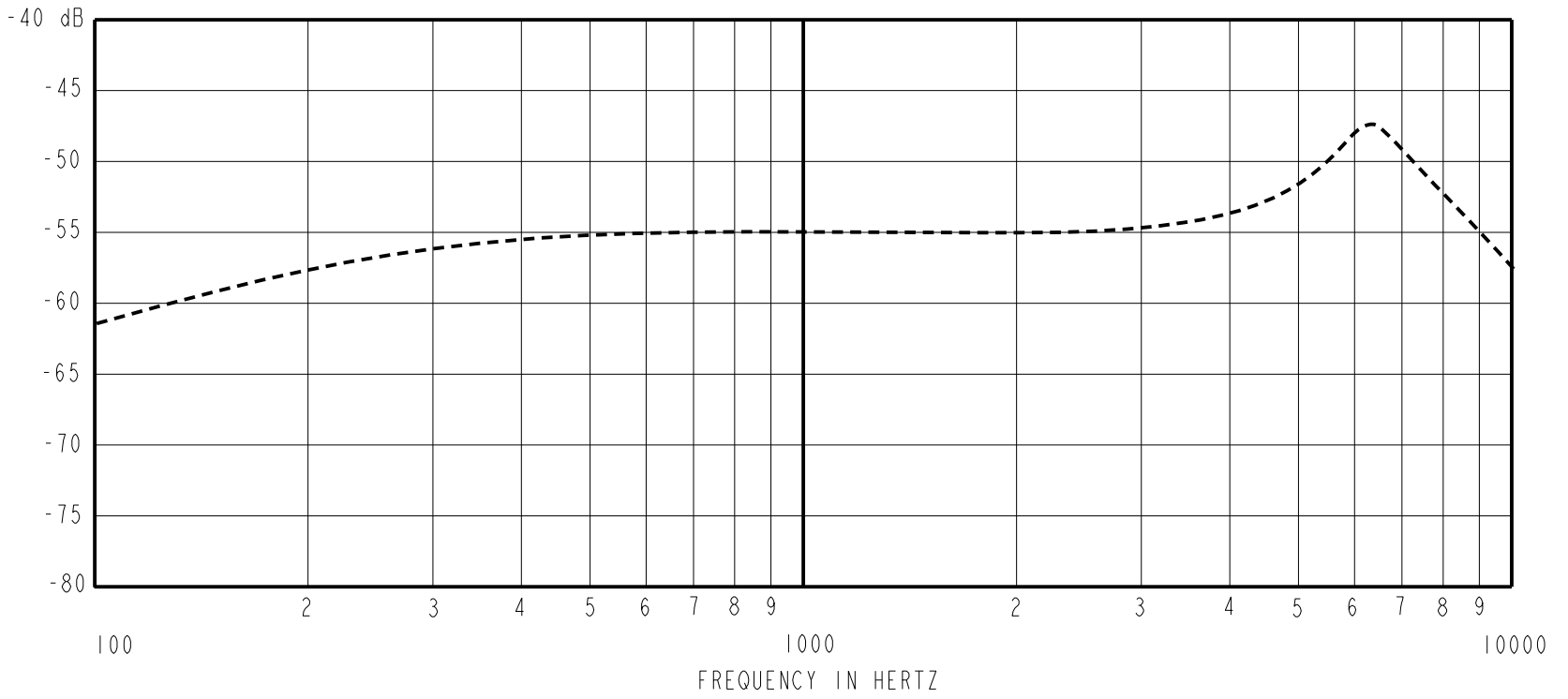

FREQUENCY	SENSITIVITY			DEVICE CONFORMITY	
	MIN.	NOM.	MAX.	RANGE OF DEVIATION FROM 1KHz	
100	---	-61.0	---	-10.0	-3.0
1000	-57.5	-54.5	-51.5	0.0	0.0
≈6400	---	-47.5	---	+4.0	+10.0

- NOTES: 1. CASE CONNECTED TO NEGATIVE TERMINAL.
 2. MICROPHONE TO BE FUNCTIONAL WITH 1.6 VDC SUPPLY.
 3. TYPICAL SENSITIVITY TO HUMIDITY AT 1000Hz IS 0.03 dB/%RH
 4. SENSITIVITY AND NOISE VALUES INDICATED ON THIS SPECIFICATION ARE VALID AT 50% HUMIDITY.

PORT LOCATION	DC SUPPLY	AMPLIFIER CURRENT DRAIN	SENSITIVITY CHANGE ON REDUCING SUPPLY TO 0.9VDC	"A" WEIGHTED NOISE (1 kHz EQUIV. SPL)	OUTPUT IMPEDANCE OHMS		
					MIN.	NOM.	MAX.
12S	1.3V	50 μA MAX.	3 dB MAX.	29.0 dB MAX.	2800	4400	6800

Revision	C.O. #	Implementation Date	RELEASE LEVEL	REVISION
G	MI0105774	10-31-14	Active	G

KNOWLES ELECTRONICS
 ITASCA, ILLINOIS U.S.A.

WHEN TEST LIMITS ARE USED TO ESTABLISH INCOMING INSPECTION ACCEPTANCE/REJECTION CRITERIA, CORRELATION OF TEST EQUIPMENT WITH KNOWLES IS ALSO REQUIRED FOR ELIMINATION OF EQUIPMENT AND TEST METHOD VARIATION

TITLE: **MICROPHONE**
 PERFORMANCE SPECIFICATION

TM-24546-C36
 SHT 2.1

DR. BY	DATE
MMM	1-4-06
CK. BY	DATE
GJP	1-5-06
APP. BY	DATE
GJP	1-5-06